

QB
62
F6



Class QLB 631

Book . F 6

Copyright N^o _____

COPYRIGHT DEPOSIT.

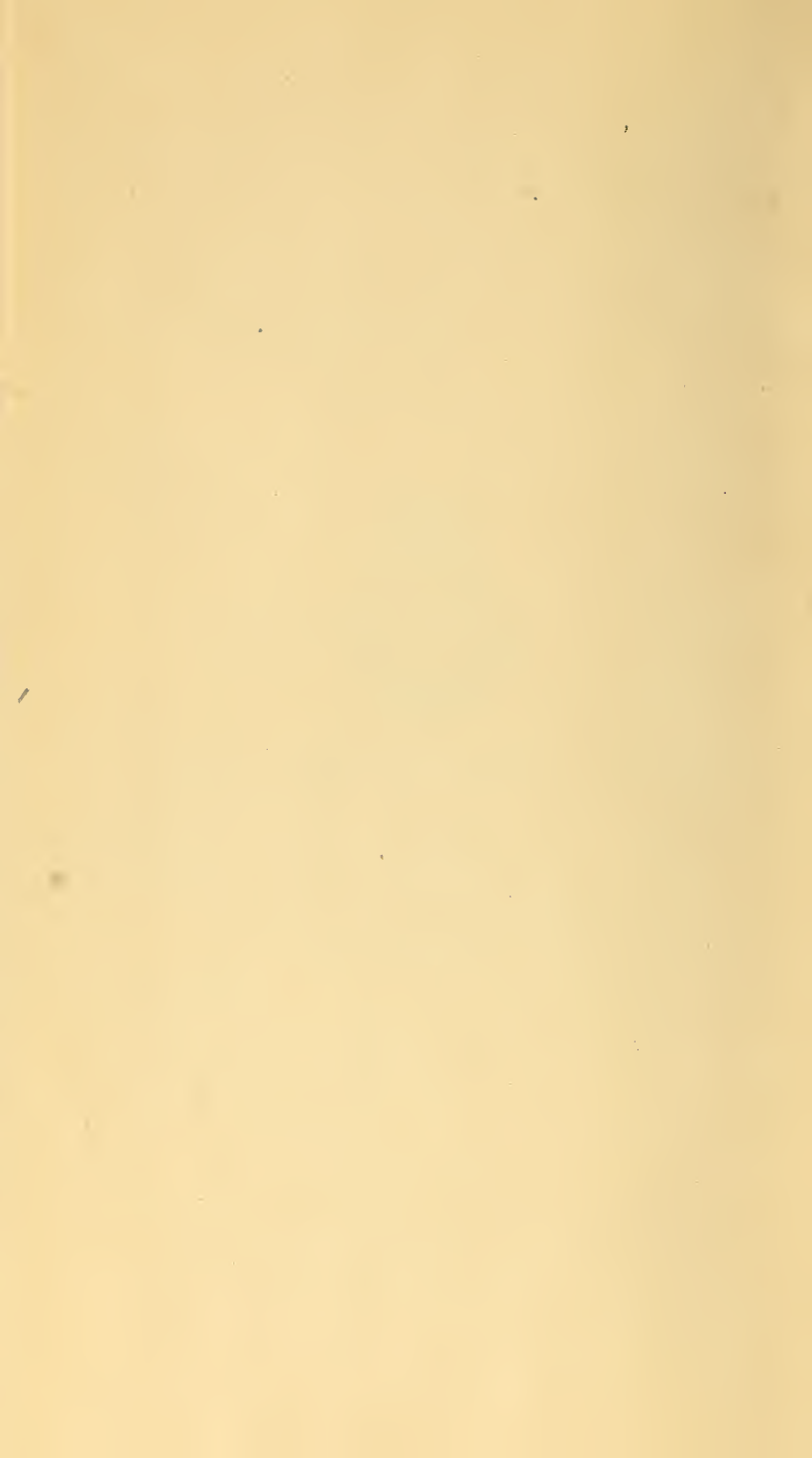

COURSE XV
Booklovers Reading Club
Hand-Book

FIVE WEEKS' STUDY OF ASTRONOMY

Professor CHARLES A. YOUNG

Sir ROBERT S. BALL

M. CAMILLE FLAMMARION

Professor GEORGE C. COMSTOCK

Professor HAROLD JACOBY

And Others

QB62
76



The Booklovers Library





ISSUED FROM THE PRESS OF
THE *BOOKLOVERS* LIBRARY
1323 WALNUT ST., PHILADELPHIA

Repr 18 Jan 08 E.S.





Robert Bell

THE BOOKLOVERS READING
CLUB HAND-BOOK TO AC-
COMPANY THE READING COURSE
ENTITLED, *FIVE WEEKS' STUDY*
OF ASTRONOMY —————



SEYMOUR EATON

Librarian

FREDERIC W. SPEIRS, Ph.D.

Educational Director

THE LIBRARY OF
CONGRESS
TWO COPIES RECEIVED
DEC. 31 1901
COPYRIGHT ENTRY
Nov. 2-1901
CLASS *a* XXc. MO.
20209
COPY B.

COPYRIGHT, 1901
THE BOOKLOVERS LIBRARY

Q B 6 2
~~F 6~~ .F 6

THE LIBRARY OF CONGRESS
PHOTODUPLICATION SERVICE
9550 GARDEN ASH DRIVE
BETHESDA, MARYLAND 20814

FIVE WEEKS' STUDY OF ASTRONOMY

Course *XV*: Booklovers Reading Club

BOOKS SELECTED

FOR THIS READING COURSE

by

Professor CHARLES A. YOUNG



FIVE WEEKS' STUDY
OF ASTRONOMY

TALKS *and* LECTURES

by

Sir ROBERT S. BALL

and

M. CAMILLE FLAMMARION

and

Professor GEORGE C. COMSTOCK

and

Doctor HAROLD JACOBY

*These papers by Sir Robert Ball, M. Flammarion
and Professor Comstock have been prepared
especially for readers of this course.*

EDITORIAL NOTES

by

Professor WILLIAM J. HOPKINS



A WORD *from* THE DIRECTOR



HERE are many books on astronomy intended for the general reader, but there are few that can meet successfully the test which we applied in making the selection for this course. We required that the books which we gave our readers should be authoritative in matter and attractive in presentation. In our search for works which would satisfy the double standard of scientific spirit and popular form we enlisted the aid of Professor Charles A. Young, of Princeton University, who by virtue of his

A WORD FROM THE DIRECTOR

investigations of the sun, ranks among the great astronomers of the world. Professor Young's long experience as a teacher of the science has given him an appreciation of the needs of the readers for whom this course is specially designed, and has made his guidance in the choice of books peculiarly valuable.

The four papers included in the handbook represent a most interesting group of astronomers. Sir Robert Ball, director of the great observatory at Cambridge, England, is equally famous for his scientific achievements and his facility in the popular presentation of an abstruse science. His style is as clear as crystal, and one who reads his books does not wonder that he attracted in London the largest audience which has ever gathered to listen to a lecture on a scientific subject. The paper which he has contributed to our handbook is a capital illustration of his simple, lucid exposition.

In striking contrast with the great English scientist stands the famous French astronomer, Camille Flammarion. The difference in personality and method of thought is clearly reflected in the papers of these two notable men as they are brought together in this handbook. M. Flammarion, the poetic popularizer of astronomical science, is regarded by many of his fellow-workers

A WORD FROM THE DIRECTOR

as unsound and visionary in some of his theories, particularly those which touch the inhabitants of other planets, but the most critical are forced to admit that he has done much solid scientific work. The enthusiastic plea which he makes in his article for the study of astronomy as an essential part of the general culture of life is thoroughly representative of his point of view.

Professor Comstock, who is one of the most prominent of the younger astronomers of this country, has contributed a paper which is very similar in scope and purpose to that of M. Flammarion. The reader will be interested in comparing the articles. Dr. Jacoby, professor of astronomy at Columbia, has given directions for the construction of a simple piece of apparatus, on the theory that "it is always better, in studying science, to do something ourselves rather than merely talk about the discoveries of others."

The reader will find that the suggestions of the Topical Outline are very helpful in systematic study. Two of the three books cover the general subject of astronomy, and the outline indicates the most effective method of fitting these two treatises together. It also brings the articles and the Illustrative Selections into proper relation with the books, and thus unifies the course.

The story to be told leaves the marvels of imagination far behind, and requires no embellishment from literary art or high-flown phrases. Its best ornament is unvarnished truthfulness.

Agnes M. Clerke

The Idea of the Course



FOR the many persons—perhaps many thousands of persons—who would know more of the wonders of astronomy, but can spare neither the time nor the effort required in an elaborate system of instruction, this reading course has been designed. No knowledge can be acquired without effort, but it is the aim of this course to simplify the subject and present it in interesting form. The knowledge of mathematics required for intelligent reading is slight, and the reader who has followed the suggestions of the handbook will possess at the end something worth having. He will know the principal stars by name, and will understand comets and meteors. He will have a reasonably clear idea of the relations of the bodies that make up the solar system, and he will be able to speak intelligently of the present condition of each of the planets and of their probable destiny. He should have, also, some familiarity with the present state of belief as to the way in which our system was formed, and the way in which stellar systems different from ours are now forming. This in itself is worth while; and the student who would go more deeply into the subject will find himself equipped for the task.



HINTS AND SUGGESTIONS TO THE READER

The systematic study of any science may be undertaken in either of two ways; observation may begin at once and the observations studied afterward—this is necessarily the way in which a science develops—or the known facts may be learned before the observation is begun. Probably neither of these methods, in its extreme sense, is the better. It is doubtful whether much is to be gained by a sudden plunge into observation, although there must be some survey of the field that is to be covered. The student who confines himself to observing will miss much that he should see or will be long in seeing it; and much that he does see will have for him no meaning. As Serviss says, in one of the books which is before you, "Of course, one could sweep over the heavens on a starry night and see many interesting things, but he would soon tire of such aimless occupation. The observer must know what he is looking at in order to derive any real pleasure or satisfaction from the sight." Moreover, little or nothing would be gained by any individual

THE BOOKLOVERS READING CLUB

observer in such a way, except, perhaps, some notion of the immensity of space and the littleness of himself and all that concerned him. That might be worth while.

It will be best to carry the observations along with the study, as far as possible, and it is assumed that the reader has at the start some acquaintance with the heavens—their appearance on a fine night, for example, the phases of the moon and its motion, differences in brightness of stars, the Milky Way, the difference in appearance of stars and planets. You must have seen plenty of meteors or shooting stars, possibly some remarkable ones, and you may have seen a comet. If you have seen but few of these things, take the first opportunity to observe them. Spend as much as you will of the first fine evening where the view is unobstructed, and absorb all that you can of the sight which is spread before you. Perhaps you may begin to appreciate dimly the immensity of space and the smallness of the part our earth plays. In the dark spots between the bright stars you will see vaguely a multitude of other stars too faint to be seen directly by the unaided eye. Do not bother with a glass this first time.

Then take up the three books upon which this course is based, and begin the more serious study on the following topical plan.

TOPICAL OUTLINE

O F T H E C O U R S E

1. History—from the earliest records to modern times.

Clerke, Fowler, and Gore, sec. I, chap. I.

Somewhat similar matter on this topic is contained in every text-book on astronomy.

2. History—the nineteenth century.

Clerke, Fowler, and Gore, sec. I, chap. II.

In these two chapters you will meet the names of the men who have done most to advance the science of astronomy, and other branches of science as well. You should remember the particular things for which each is best known and should have some idea of the time in which each lived. It is hardly worth while to attempt to commit dates to memory unless you have a special fondness for that sort of thing. This topic is very broad in scope, for what has been done in the past century comes near including all the refinements of method and all the discoveries that have contributed most to our present knowledge of the universe, slight as that knowledge is. The reader who would become more of a student will do well to read carefully Agnes M. Clerke's *Popular History of Astronomy during the Nineteenth Century*, listed in the Supplementary Reading. Such a study should follow the completion of this course.

3. The Earth and its Rotation.

Todd, chap. II.

Clerke, Fowler, and Gore, sec. II, chaps. I, IX, X.

Some knowledge of the geological history of the earth and of the development of life-forms will be found interesting. All branches of science are so bound together that it is impossible to study one branch without wishing to know more of others. There is some conflict between geologists and astronomers as to the earth's age; the geologists needing more time than the astronomers are willing to give. Probably the astronomers have the best of it. In this connection read the extract from Flammarion's *Popular Astronomy*, on page 94 of the handbook.

4. General Aspect of the Heavens; how position is defined.

Serviss, pp. 1-4.

Todd, chap. v.

Clerke, Fowler, and Gore, sec. II, chap. III.

The mathematical ideas involved are, for the most part, simple. If any difficulty is found with any part of this chapter, take a globe and transfer the drawings to its surface. A blackened globe is best, such as is used in most school rooms, but if such a globe is not to be had, an ordinary rubber ball will do very well.

5. Time and its Measurement.

Clerke, Fowler, and Gore, sec. II, chap. v.

Todd, chap. IV.

FIVE WEEKS' STUDY OF ASTRONOMY

An interesting account of time distribution selected from one of the books recommended by Professor Young, Dr. Herbert A. Howe's *A Study of the Sky*, will be found on page 98 of the handbook.

6. The Earth; its motion.

Clerke, Fowler, and Gore, sec. II, chaps. II, IV.

7. The Moon and its motions.

Todd, chap. III.

Clerke, Fowler, and Gore, sec. II, chap. VI.

This is a good place to begin observation. The moon is easily observed, even with the naked eye; and with any kind of a glass the character of its surface comes out very clearly. Careful examination of its surface may be postponed until its history is considered under a later topic. Observe the moon in its different phases.

8. Planets and their Satellites.

Todd, chaps. IX-X.

Clerke, Fowler, and Gore, sec. II, chap. VII.

See if you can pick out a planet with your glass. Note the difference between its appearance and that of a star. Jupiter shows an evident disk, and blazes out like a little moon; and if the season is favorable, you may distinguish the phases of Venus.

9. The Sun.

Todd, chaps. VI-VIII.

Clerke, Fowler, and Gore, sec. II, chap. VIII ;
sec. III, chaps. II-III.

Excellent plates of the sun's surface, showing spots and prominences, are to be found in Sir Robert Ball's *The Story of the Heavens*, listed in the Supplementary Reading.

10. Tides and their effects.

Clerke, Fowler, and Gore, sec. II, chap. XIII.

The action of tides is of great importance and will be considered again under later topics.

11. Telescopes and other instruments.

Todd, chap. XVIII.

Clerke, Fowler, and Gore, sec. II, chap. XIV-
XVII.

It is well to read over the whole of the reference, but for the average student it is not necessary to become familiar with all the accessory instruments. You should get a good idea of the purpose of each instrument, and should appreciate the care and skill required of the astronomer. The chapter on telescopes should be studied more carefully. See that you get from this chapter a clear idea of the difference between a reflector and a refractor, and of the advantages of each. It would be a good plan, also, to learn the difference between a refracting telescope and an opera-glass; but for this you will have to refer to some modern text on physics. The refracting telescope is necessarily long, if of high power, unless the most modern construction is adopted. By this con-

FIVE WEEKS' STUDY OF ASTRONOMY

struction the telescope is virtually folded upon itself, the three sections lying side by side. No glass larger than a field-glass is made in this way, the highest power being about 12 diameters. In the opera glass the eyepiece is concave instead of convex, and is placed much nearer to the object-glass, so that the length of the instrument is not great; but the field of view is smaller than in the other form, which is a disadvantage.

12. Distances and Dimensions of Heavenly Bodies.

Clerke, Fowler, and Gore, sec. II, chaps. XI–XII.

For purposes of comparison read the selection on this topic from Flammarion's *Popular Astronomy* on page 103 of the handbook.

13. The Solar System.

Todd, chap. IX.

Clerke, Fowler, and Gore, sec. III, chap. I.

The attention of the reader is specially directed to the admirable statement of the nebular hypothesis which we have quoted from Agnes M. Clerke's *Popular History of Astronomy during the Nineteenth Century*. It appears on page 107 of the handbook.

14. The Terrestrial System.

Clerke, Fowler, and Gore, sec. III, chap. V.

Serviss, chap. V.

Excellent plates of the moon will be found in Sir Robert Ball's *The Story of the Heavens*. They are

from drawings and photographs. Refer to the plates in chapter III of Todd's *Stars and Telescopes*. Read Sir Robert Ball's paper contributed to this course, *The Moon's Story*; and also Professor Holden's *The Birth and Death of the Moon*, in *Harper's Magazine* for August, 1901, if that is available. The article contains some fine photographs made at the Lick Observatory.

The history of the earth and the moon, so far as we can guess at it, shows an example of the action of tides on a great scale. The result, however, is somewhat different from that in the case of any other planet, as will appear on further study.

Follow the text of Serviss, chapter v, in your observations. If you have any difficulty, it is likely to be a lack of steadiness in holding the glass. This is not so troublesome in the case of the moon as it will be when you begin on the stars and planets, and the difficulty will be about in proportion to the power of your glass. An opera-glass with a power of about 4 does very well, and if you have a field-glass besides, with a power anywhere from 7 to 12, you will see much more than you can see with the opera-glass. If the lack of steadiness is found to be troublesome, the difficulty may be remedied in a simple way. In observing the stars, some such device as that recommended in the next paragraph will be found almost necessary for most observers.

Having selected the best available spot for observing—an open field is best, but a skylight or even an upper window will do—arrange a support for your glass. If the place is a window, the support may be fastened at the edge, either inside or outside. If the field is selected, drive a stake and

FIVE WEEKS' STUDY OF ASTRONOMY

at a convenient height fasten a cross-piece by a single screw. The screw may be tightened until the cross piece will just turn upon it, but will stay in any position in which it is put. The glass may be clamped or tied on this cross piece. It would not be a difficult matter to set the screw nearly in the polar axis, so that the mounting should be roughly equatorial; and the addition of another cross-piece fastened by a screw to the top of the first, as the first is to the stake, would make the mounting complete. These arrangements are not necessary, but they will be found convenient, and they are easily made. The height may be suited to the observer, either standing or sitting.

In all observations it will be a help to have a note-book at hand. Anything of interest should be recorded.

15. The Inner Planets: Mercury and Venus.

Todd, pp. 104-110.

Clerke, Fowler, and Gore, sec. III, chap. IV.

Serviss, p. 139.

16. Mars.

Todd, p. 111; chap. XI.

Clerke, Fowler, and Gore, sec. III, chap. VI.

Serviss, p. 140.

17. The Outer Planets.

Todd, pp. 111-147.

Clerke, Fowler, and Gore, sec. III, chaps. VI, VIII, IX, X.

18. Comets and Meteors.

Todd, chaps. XII–XIV.

Clerke, Fowler, and Gore, sec. III, chaps. XI–XIII.

The accounts of famous comets are of interest, but it is hardly to be expected that the reader will remember the details. Not very much is known with certainty about the tails of comets, but a comet certainly wastes its substance at a great rate every time it approaches the sun, which accounts for the used up appearance of the planetary comets. The connection between comets and meteors is pretty well established, and the periodic showers of meteors are supposed to be "the debris of ancient, but now disintegrated comets, whose matter has become distributed round their orbits." In this connection it is interesting to note that the great shower of the Leonid meteors expected in 1899 or 1900 has, so far, failed to keep its appointment, probably because of the disturbance made by one of the outer planets. It is supposed that the comet from which these meteors are derived was introduced into our system by Uranus in 126 A. D.

19. Stars and Constellations.

Todd, chaps. XV, XVII.

Clerke, Fowler, and Gore, sec. IV, chaps. I–VI.

A mere reading of descriptions of the stars and their positions is of little value. Observation should accompany the reading; and for that it will be best to follow *Astronomy with an Opera-Glass*. The order of work will depend on the season. What an observer will get from such work will de-

FIVE WEEKS' STUDY OF ASTRONOMY

pend on himself. There is scarcely a limit to the extent to which it can be carried, but at least you should be able to recognize the brightest stars and should know the places of the familiar constellations. If you can find some double stars and the conspicuous clusters and nebulae, so much the better.

20. The Cosmogony: Life and Death of Stars and Planets.

Todd, chap. XVI.

Other matter bearing upon this subject is contained in the references already given, but so scattered through them that it is impossible to refer to it specifically.

21. Structure of the Visible Universe.

Clerke, Fowler, and Gore, sec. IV, chap. VII.

Astronomy as a Culture
Study: *A Ten-Minute Talk*
by GEORGE C. COMSTOCK

Astronomy as a Culture Study: *A Ten-Minute Talk* by GEORGE C. COMSTOCK

Professor George Cary Comstock, although of New England stock, was born in Wisconsin and has spent most of his life in the Mississippi Valley and the region of the Great Lakes. During his student years at the University of Michigan, and for a short time thereafter, he was engaged in field work under the Corps of Engineers, U. S. A. He served successively as an assistant in the observatories at Ann Arbor and Madison, and was for a time engaged upon astronomical calculations in the *Nautical Almanac* office at Washington. During this period he also pursued the study of law and was admitted to the bar, but never engaged in practice. After serving for two years as professor of mathematics and astronomy in the Ohio State University, he was called to the professorship of astronomy in the University of Wisconsin and the directorship of the Washburn Observatory, which position he still holds. He is secretary of the Astronomical and Astrophysical Society of America. His published works include a treatise upon the *Method of Least Squares*, a *Text-book of Astronomy*, five volumes of the Washburn Observatory publications, and numerous scientific papers scattered through the periodical literature of astronomy.

Modern life depends for its very existence upon the physical and natural sciences, whose applications are so closely twined into its warp and woof that not the pattern only but the

fabric's very substance must be destroyed by their elimination. On the material side, food and raiment, shelter and transportation are among their indispensable contributions to human welfare; and if things moral, intellectual, and social are in their substance less closely bound to the sciences, they are, at least, disseminated and brought home to mankind through the same agencies that minister to its material needs. Each of the great sciences has its especial relation to the practical affairs of life, and astronomy stands among them with its aid to navigation and commerce, and with its study of the sun, the fountain-head of all terrestrial energies. But it is with quite a different phase of the science that we are here concerned—its culture side, its capacity for bringing into human lives, which perforce run in artificial channels, the joy of contact with nature and knowledge of God's way in nature. And, in sooth, astronomy possesses such a culture side, singularly accessible and singularly attractive to whoever will seek it at first hand and will study the heavens themselves, using books as a guide but not as a substitute for nature.

One need not wonder that astronomy is the oldest of the sciences, that prehistoric man possessed and transmitted to us through his posterity a knowledge of the sky that, though crude and limited, was in substance more accurate and more complete than his knowledge of the earth and its

FIVE WEEKS' STUDY OF ASTRONOMY

complexity. Despite their far-off air of mystery, stars are simpler than stones or plants or animals, and by their beauty challenge an attention oft denied to meaner things; so that a knowledge of the stars grew up in the dawn of civilization because they presented problems essentially simple to minds convinced that these same problems were immensely important. Egyptian and Chaldean, priest and astronomer, alike believed that the issues of life were determined in the heavens, that the course of human events might be predicted from the stars; and in this practical and often sordid spirit the stars and their courses have been studied even to our own day, for the belief in astrology is not yet quite extinct, although Kepler, three centuries ago, was probably the last astronomer of eminence to cast horoscopes for a living and to argue with his conscience over the right and wrong of such a practice.

But the occult element has faded from the sky, and to the modern student the stars are a part of nature, governed by the same physical and chemical laws that rule the earth, and challenging his interest as a part of nature on an even footing with flower or feather, fin or fur. But which of these can rival the sky as a subject of contemplation and study for a mind absorbed chiefly by the daily cares of life, from which it turns for rest and recreation, for the joy, and uplifting, and

inspiration that come from nature's own hand? Flowers and foliage are, for the most part, limited to one season of the year, while the stars shine winter and summer alike. Birds and animals must be sought in their appropriate haunts, while the heavens need no expedition for their search, but stand open to view alike from the crowded city roof-tops and from the loneliest camp-fire of Alaskan wilds. Nor do the stars call for any special apparatus to charm forth their attractiveness—telescope, or camera, or spectroscope. Often in the wakeful hours of midnight travel has the writer of these lines found pleasure and repose in lifting the curtain of his car window to look upon and admire celestial friends whisked into sight and out again as a winding track changed rapidly the point of view.

“Why did not some one teach me the constellations in my youth?” cried Carlyle, and a greater philosopher than he, who did thus learn them, proclaims that two things alone awake in his mind a sense of awe—God's moral order and the starry skies. Once made familiar, the sky is a life-long source of joy; but it must be learned, learned by heart, as the children say, for most men grow up with small appreciation of its charm, so that, in the language of old Gobbo, they are sand-blind to its beauty, high-gravel blind to its wealth of changing aspects.

Do you know from your own experience that

FIVE WEEKS' STUDY OF ASTRONOMY

the sky turns round, that the stars rise and set like the sun and moon? Many a man who has lived beneath them for half a lifetime has not learned so much. Do you know that the stars of the winter sky are not the stars of summer, and have you watched the procession of the constellations through which this change is made? Have you seen in the spring time Orion and his followers, the big dog, Canis Major, and the little dog, Canis Minor, glide each night a little earlier down the western sky until, with the advancing season, they are lost in the twilight and replaced by the Lion and the Maid, Leo and Virgo, who usher in the summer, and by the Scorpion and Hercules, who proclaim the fulness of the mid-year? Long before the invention of almanacs and calendars mankind relied upon such signs as these for the coming of seed time and harvest; and is it pure gain that in their place there has been set up the patent medicine counselor and the insurance manual of times and seasons?

You have seen the moon sweep majestically across the sky through half a dozen constellations in a fortnight, but have you watched the slower pace and the serener beauty of a planet that, like Venus, creeps modestly forth from the glare of sunset and night by night, month after month, grows in brilliancy until it stands as a celestial beacon commanding even the most heedless eye and stirring even the dullest churl to admiration

THE BOOKLOVERS READING CLUB

of its splendor? A glorious spectacle and worthy to be followed even in its declining course as, with diminishing brightness, the planet moves back toward the sun, setting each night a little earlier until it is lost in the sun's radiance, only to reappear a little later in the morning sky, there to run another course. Or follow Jupiter which, in these early years of the twentieth century, is the brilliant ornament of the midnight sky of summer, rising and setting with the fainter stars about him, but also with a motion of his own, drifting through the constellations slowly but steadily, so that even the unaided eye may detect his motion after a few nights of careful watching. And so may Mars and Saturn be followed and the paths marked out in which they move, a long stride toward the east, followed by a shorter one to the west, and again a long one to the east in endless succession, easy to understand in its general character but puzzling in the highest degree to many a generation of baffled astronomers who sought to explain its every feature and to foretell the planet's course. Patience and a keen eye will secure many a glimpse of Mercury, though the tradition runs that, in the more northern latitude of Poland, to the very end of his long life Copernicus sought it in vain. Even Uranus comes within the range of naked eye vision, as with slow pace it picks its way among the constellations of the zodiac, unseen by a hundred genera-

FIVE WEEKS' STUDY OF ASTRONOMY

tions of astronomers until detected little more than a century ago by the telescope of Herschel. A striking witness, through its present visibility, that the known thing is easier seen than the unknown, though both be equally bright.

And the stars themselves, fixed stars, that, unlike the planets, abide ever in the same constellations, forming among themselves indissoluble groups and families that come and go, each at its appropriate season, with an unrivaled punctuality that regulates the clocks and watches of mankind today as five thousand years ago the same stars, moving at the same unvarying pace, regulated the lives of men to whom clocks and watches were unimagined things. Are not these admirable for their well ordered beauty and their changeless duration? Orion and the Pleiades, the Great Bear, the Scorpion, the Sickle and that glorious celestial girdle of shimmering light that men call the Galaxy, or Milky Way—these have come to us substantially unchanged from the days of David and Homer, of Job and the earliest civilization that grew up in the valley of the Nile. And what else is there of such undoubted antiquity and so easily accessible to modern eyes? Where else in art or nature shall we find the veritable objects about which twine more than half a hundred centuries of admiring myth and legend, of reverent worship, and of coldly scientific study? The glorious, the immutable, the eternal stand here as

THE BOOKLOVERS READING CLUB

nowhere else, revealed to whatsoever eye will look upon them, to whatsoever mind will contemplate them and drink in their lessons at first hand.

But, in very sooth, even the stars are not immortal. The hand of time is upon them working slowly, so slowly that literally "a thousand years are but as a day when it is past," but working so surely that we may not doubt that even the celestial hosts shall pass away.

"The cloud-capp'd towers, the gorgeous palaces,
The solemn temples, the great globe itself,
Yea, all which it inherit, shall dissolve,
And, like this insubstantial pageant faded,
Leave not a rack behind."

Would you behold the transitoriness of even the heavenly bodies, the passing away of things that come not back again, then look into the early morning sky of August and behold the shooting stars that for a moment dash across the firmament and then are lost forever. So flagrant is their contrast with the abiding stars that many a generation of men refused to believe them of celestial origin, and in the quaint church legends of the olden time they are christened "the fiery tears of St. Laurence," after the patron saint of the day upon which they are wont to appear. But these tears fall from the sky not on St. Laurence's day alone; though less abundant, they may be seen by the patient observer on any clear

FIVE WEEKS' STUDY OF ASTRONOMY

and moonless night, and he who has once seen them, counted their number and watched their paths gleaming like a rocket's trail, will turn to the astronomer and his books, seeking an explanation of this celestial bombardment with a pleasure and interest unknown to the student of books alone.

But shooting stars are not the only transient features of the sky; their brother, the fire-ball, and their cousin, the comet, are by no means infrequent visitors, always sure of a welcome from the ubiquitous reporter whose published account of and guidance to them would oftentime prove more valuable had his eyes learned to know the sky before his victims' arrival. Of even greater interest and moment than these chance visitors is the blazing forth in a night of a temporary star, such as that of February, 1901, which, unheralded and unexpected, rose in a few hours from complete invisibility to be the rival of the brightest stars in the sky, and then slowly died away, its decline extending over many months. This is no birth of a new star, as it is sometimes called, but the fiery transformation of an old one, perchance long since extinct and cold, into something new—a tremendous catastrophe like that foreshadowed in the stirring words of the *Dies Iræ*, whose eloquent Latin, *Solvat sæclum in favilla*, is feebly rendered by the English words, "By fire shall the world be tried."

THE BOOKLOVERS READING CLUB

The study of the sky and its brilliant throng of twinkling lights is not primarily a matter of telescopes, of observatories, and of a class of men set apart for it alone. Like faith, hope, and charity, the heavens and their culture stand open to the layman without intervention of either priest or astronomer, although each of these, if true to his vocation, may do much to aid, and guide, and instruct his fellow-men. A simple star-map and, it may be, an opera-glass, a clear sky, and an active mind are all the equipment really required for the culture study that we have in mind. A well chosen book or two will save much time and some vexation by suggestions of where to look, what to see, and what to do, much as the catalogue may serve as guide to a picture gallery; but who would wish his guide-book to be a substitute for the pictures, or his text-book to supplant the heavens as a subject of study? Beware of these, for 'twas of such the greatest of English poets wrote:

“Small have continual plodders ever won
Save base authority from others' books.
These earthly godfathers of heaven's lights
That give a name to every fixed star
Have no more profit of their shining nights
Than those that walk and wot not what they are.”

George Comstock

The Moon's Story: *A*
Lecture by SIR ROBERT BALL

The Moon's Story: *A*

Lecture by SIR ROBERT BALL

Sir Robert Stawell Ball is the eldest son of the late Robert Ball, a distinguished naturalist and author. After his graduation from Trinity College, and a novitiate as astronomer to the Earl of Rosse, he held chairs in the Royal College of Science for Ireland, and in the Universities of Dublin and Cambridge. He relinquished the office of Royal Astronomer of Ireland to become director of the Cambridge Observatory. Sir Robert Ball has lectured before leading institutions of the United Kingdom, and his papers on mathematics and physics have appeared constantly during the last twenty years. His recent publications include *The Story of the Sun*, *The Story of the Heavens*, *In the High Heavens*, and *Great Astronomers*. His last extensive work, *A Treatise on the Theory of Screws*, appeared in 1900. Frequent honors have come to him. He received the Cunningham gold medal of the Irish Academy for a series of memoirs on dynamics; he has held the presidency of the Royal Zoological and Royal Astronomical Societies and of the Mathematical Association, and in 1886 he was created a knight of the realm.

I think there is no chapter in modern science more remarkable than that which I here propose to describe. It has, indeed, all the elements of a romance. I am to sketch an event of the very greatest moment in the history of this universe, which occurred at a period of the most

extreme antiquity, and has been discovered in the most remarkable manner.

The period of which I write is far more ancient than that of the pyramids of Egypt or of any other monuments erected by human effort. It is even more early than that very remote time, hundreds of thousands of years ago, when man himself first came upon this globe. Our retrospect has to pierce right through those vastly protracted cycles which the geologists have opened up to us. We speak of a period long anterior to the ages during which our continents were being sculptured into their present mountain chains and river courses. We have to look through those periods still earlier when great animals, now long extinct, flourished on this earth. The time of which I write is more remote than that very remarkable epoch in earth history during which the great coal forests flourished. It is earlier than the supreme moment, countless millions of years ago, when living organisms first became inhabitants of this globe. Even here, however, our retrospect must not stop. We have yet once more to look back through certain anterior periods to a time when our earth was in its earliest youth. The chapter of history about which I am now writing is, indeed, in the very dawn of things terrestrial.

It might be thought that it would be utterly impossible for us to learn anything with regard to what took place at a time so immeasurably ante-

FIVE WEEKS' STUDY OF ASTRONOMY

rior to all sources of tradition, and, indeed, to all the ordinary channels for obtaining knowledge by observation. It fortunately happens, however, that the darkness of this early period is illumined by a bright and steady source of light which will never deceive us if only we will follow it properly. Our trustworthy guide is to be the pen of the mathematician, for it is well known that, unless we are going to dispute the fundamental proposition that two and two make four, we cannot impugn the truths which mathematics disclose. This science knows no boundaries of space. It recognizes no limits in time. It is ever ready for discussing operations which take place, either in the millionth part of a second, or in the lapse of uncounted millions of centuries. The processes of mathematics are alike available for tracing out the delicate movements in the interior of a molecule not one-millionth part of the size of a grain of sand, or for investigating the properties of space so vast that the whole solar system occupies only an inconsiderable point by comparison. Let us, therefore, see what this infallible guide has to teach us with regard to that momentous epoch in the history of our system when the moon was born.

Our argument proceeds from an extremely simple and familiar matter. (Every one who has ever been on the sea-shore knows the daily ebb and flow of the waters, which we call the tides.

Long ere the true nature of the forces by which the moon acts upon the sea was understood, the fact that there was a connection between the tides and the moon had become certainly known. Indeed, the daily observation of a fisherman, or of any one whose business was concerned with the great deep, would have taught him that the time of high water and the time of full moon stood at each place in a certain definite relation. The fisherman might not have understood the precise influence of the moon upon the tides, but if he had observed, as he might in some places, that when the moon was full the tide was high at ten o'clock in the morning, it would be perfectly obvious to him that the moon had some special relation to this ebbing and flowing of the ocean. Indeed, we are told of some savage race who, recognizing that the moon and the tides must be associated, were still in some considerable doubt as to whether it was the moon which was the cause of the tides or the tides which were the cause of the moon.

The ebbing and flowing of the tide opens up this chapter in remote history, which we can now explore mainly by the help of the researches of Professor George Darwin. For as the tides course backward and forward, sweeping to and fro vast volumes of water, it is obvious that the tides must be doing work. In fact, in some places they have been made to do useful work. If

the water as it rises be impounded in a large reservoir, it can be made to turn a water-wheel as it enters, while another water-wheel can be driven as the reservoir empties itself a few hours later. Thus we produce a tidal mill. It is quite true that so long as coal remains tolerably cheap and steam power is consequently readily available, it is not often possible to employ the direct power of the tides in an economical manner. For our purpose it is merely necessary to note that, day after day, week after week, year after year, the tides must be incessantly doing work of some kind or other.

Every practical man knows that a certain quantity of work can be done only by the expenditure of a certain quantity of energy. He also knows that there is in nature no such thing as the creation of energy. It is just as impossible to create out of nothing the energy which should lift an ounce weight through a single inch as it would be to create a loaf of bread out of nothing. If, therefore, the tides are doing work—and we have seen that they undoubtedly are doing work—it follows that there must be some source of energy on which the tides are enabled to draw. A steam engine is able to put forth power because of the energy developed from the coal which is continually supplied to the furnace. But where is the equivalent of the coal in the great tidal engine? We might at first hazard the supposition that, as the moon

is the cause of the tides, so we must look to the moon to provide the energy by which the tides do their work. This is, however, not exactly the case. The match which lights the fire under a steam boiler is in one sense, no doubt, the cause of the energy developed ; but we do not therefore assert that the power of the engine is derived from the match. It comes rather from the fuel whose consumption is started by the match. In like manner, though the moon's attraction causes the tides, yet it is not from the moon that the tidal energy is drawn. There is only one possible source for the energy necessary to sustain the tides. Every one who is conversant with mechanical matters knows the important duty which the fly-wheel performs in a mill. The fly-wheel, in fact, may be considered as a reservoir into which the engine pours the power generated with each stroke of the piston, while the machinery in the mill draws on this accumulated store of power in the fly-wheel. If the engine is stopped, the fly-wheel may yet give a turn or two, for the energy which it contains may be still sufficient to drive the machinery of the mill for a few seconds. But the store of energy in the fly-wheel would necessarily become speedily exhausted and the fly-wheel come to rest unless it were continually replenished by the action of the engine.

The earth may be regarded as a mighty fly-wheel which contains a prodigious store of

FIVE WEEKS' STUDY OF ASTRONOMY

energy. That energy is, however, never added to, for there is no engine available. If, however, no energy were withdrawn from the earth, then the globe would continue to spin round its axis once every twenty-four hours forever. As, however, the tides need energy to get through their work, they abstract what they require from the store which they find at hand in the rotation of the earth. Next time you see the tides scouring up and down a river, you may reflect that the power which impels that mass of water to and fro has been obtained solely at the expense of the spinning of our globe. Indeed, the little child who digs a moat in the sand, which is filled by the rising tide, affects to a certain extent the revolution of this earth about its axis.

This withdrawal of energy from the earth is incessantly taking place along almost every coast. From day to day, from century to century, from eon to eon, energy is daily being withdrawn and daily wasted, never again to be restored. As the earth has no other means of replenishing its stores, the consequence is inevitable. The quantity of energy due to the rotation of the earth must be gradually declining. Stated in this way perhaps the intimation is not very alarming, but placed in other words, the results at which we have arrived assume the more practical expression that the tides must be gradually checking the speed with which the earth turns round. The

tides must, in fact, be increasing the length of the day. In consequence of the tides which ripple to and fro on our shores and which flow in and flow out of our estuaries and rivers, today is longer than yesterday, and yesterday was longer than the day before. I may, however, admit at once that the change thus produced is not very appreciable when only moderate periods of time are considered. Indeed, the alteration in the length of the day from this cause amounts to no more than a fraction of a second in a period of a thousand years. Even in the lapse of ordinary history there is no recognizable change in the length of the day. But the importance of our argument is hardly affected by the circumstance that the rate at which the day is lengthening is a very slow one. The really significant point is that this change is always taking place and lies always in the same direction. It is this latter circumstance which gives to the present doctrine its great importance as a factor in the development of the earth-moon system. We are accustomed in astronomy to reason about movements which advance for vast periods in one direction, and then become reversed. Such movements as these are, however, not the real architects of the universe, for that which is done during one cycle of years is undone during the next. But the tides are ever in operation, and their influence tends ever in the same direction. Consequently the

FIVE WEEKS' STUDY OF ASTRONOMY

alteration in the length of the day is continually in progress, and in the course of illimitable ages its effects accumulate to a startling magnitude.

The earth now revolves on its axis once in twenty-four hours. There was a time, millions of years ago very likely, when it revolved once in twenty-three hours. Earlier still it must have spun on its axis in twenty-two hours, while this succeeded a time when the day was only twenty hours. The very same arguments applied in those times which apply at the present, so that if we strain our vision back into the excessively remote past, we find the earth spinning ever more and more rapidly, until at last we discern an epoch when the length of the day, having declined to eight hours and seven hours, had at last sunk to something like five or six hours. This is the time when the moon's story commences. At this eventful period the earth accomplished about four revolutions in the same time that it now requires for a single one. We do not attempt to assign the antiquity of this critical moment. It must certainly have been far earlier than the time when this earth became fitted for the reception of organized life. It must have been, at least, many millions of years ago. If it be thought that the vagueness of our chronology is rather unsatisfactory, then it must be remembered that even historians, who have human records and monuments to guide them, are still often in utter uncertainty

as to the periods during which mighty empires flourished or as to the dates at which great dynasties rose or perished.

But our story has another side to it. Among the profoundest laws of nature is that which asserts that action and reaction are equal and opposite. We have seen that the moon is the cause of the tides, and we have further seen that tides act as a brake to check the speed with which the earth is rotating. This is the action of the moon upon the earth, and now let us consider the reaction with which this action must be inevitably accompanied. In our ordinary experience we observe that a man who is annoyed by another feels an unregenerate impulse to push the annoying agent away as far as possible. This is exactly the form which the reaction of the earth assumes. It is annoyed by the moon, and accordingly it strives to push the moon away. Just as the moon by its action on the earth through the medium of the tides tends to check the speed with which the earth is rotating on its axis, so the earth reacts on the moon and compels the satellite to adopt a continuous retreat. The moon is, therefore, gradually receding. It is further from the earth today than it was yesterday; it will be further tomorrow than it is today. The process is never reversed; it never even ceases. The consequence is a continuous growth in the size of the track which the moon describes around the

FIVE WEEKS' STUDY OF ASTRONOMY

earth. It is quite true that this growth is a slow one ; so, too, the growth of the oak is imperceptible from day to day, though in the lapse of centuries the tree attains a magnificent stature. The enlargement of the moon's orbit, though imperceptible from month to month, or even from century to century, has revolutionized our system in the lapse of many millions of years.

Looking back through the mists of time we see the moon ever drawing nearer and nearer to the earth. Our satellite now revolves at a distance of 240,000 miles, but there was a time when that distance was no more than 200,000 miles. There was a time, millions of years ago, no doubt, when the moon was but 100,000 miles away ; and as we look further and further back we see the moon ever drawing closer and closer to the earth, until at last we discern the critical period in earth-moon history when our globe was spinning round in a period of about five or six hours. The moon, instead of revolving where we now find it, was then actually close to the earth ; earlier still it was, in fact, touching our globe, and the moon and the earth were revolving each around the other, like a foot-ball and a tennis-ball actually fastened together.

It is impossible to resist taking one step further. We know that the earth was, at that early period, a soft molten mass of matter, spinning round rapidly. The speed seems to have been

THE BOOKLOVERS READING CLUB

so great that a rupture took place, a portion of the molten matter broke away from the parent globe, and the fragments coalesced into a small globe. That the moon was thus born of our earth uncounted millions of years ago is the lesson which mathematics declares it learns from the murmur of the tides.

Robert S. Bell

The Charm and Utility of
Astronomy: *A Lecture by*
CAMILLE FLAMMARION

The Charm and Utility of Astronomy: *A Lecture by* CAMILLE FLAMMARION

Camille Flammarion was intended by his parents for the church and was educated in Jesuit seminaries. From childhood, however, he was fascinated with astronomy and determined to devote his life to science. At sixteen he published a book entitled *The Cosmogony of the Universe*. This volume was followed three years later (1862) by *The Plurality of the Inhabited Worlds*, the book which immediately made his reputation. Since then he has done much to popularize the science of astronomy by presenting facts in a poetical, picturesque, and easily comprehended form. Most notable among his popular works are *The Marvels of the Heavens*, *The Atmosphere*, *Urania*, *Popular Astronomy*, and *Lumen*. He has also translated several books and has edited the *Astronomical Encyclopædia*. The creation of the *Monthly Review of Astronomy*, the founding of the *Astronomical Society of France*, and the establishment of the observatory at Juvisy, his summer home, M. Flammarion considers his three greatest achievements.

Is man by nature an intelligent being? Is he endowed with reason? Is he moral? Does he represent a really superior intellectual species? These are questions which scholars, moralists, and philosophers constantly ask. There are many answers, uncertain and disputable because mankind comprises all—the good and the bad, the wise and the foolish, minds which discern correctly and

others whose powers of observation are faulty. The astronomer, being led by his habits of study to judge things and beings as a whole from a high and remote standpoint and to live a life of abstraction, feels that upon this planet we are far from the absolute; that our valuations, our judgments, depend upon the imperfect, relative, and often erroneous impressions of our senses; and that from the very nature of our world, the human species is far from perfect. But that which especially impresses and constantly surprises him is that up to this time most of the inhabitants of this world have lived without knowing where they were, and without suspecting the wonders of the universe. We are indeed surrounded by wonders, yet we live blindly upon the earth like plants and mollusks.

It is not uncommon to hear people of the better class, otherwise bright and intelligent, ask, "What is the good of astronomy?" It is a little like asking of what good are music, painting, physics, of what good are all the arts and sciences; but it is less excusable, for astronomy is not only a science, it is preëminently *the* science, the one which teaches us about the universe in which we live. Without this science we should be in a state of deplorable ignorance.

In many ways we unconsciously make use of astronomy. If we but ask the day of the month, we put an astronomical question, for we owe

FIVE WEEKS' STUDY OF ASTRONOMY

to this science our calendar, and, therefore, the basis necessary for recorded history. Do we glance at a watch? Again it is a matter of astronomy, for time is reckoned by the diurnal movement of our planet upon its axis, and by the sun's crossing certain meridians. Do we drink coffee? Let us remember that if coffee-drinking has become a habit, it is so not only because the bean could from the first be transported at a low price, but also because nautical science, which directs the course of ships by determining longitude, drew its knowledge from observation of the eclipses of Jupiter's satellites. For that matter navigation could not exist without astronomy.

It would be difficult to name a subject with which astronomy is not associated. Is champagne served at the end of a meal? It is bottled sunshine. Do we taste fruit, inhale a flower's fragrance, admire a field of wheat, or feel the warmth from the hearth? All these are from the storehouse of the sun. It is the sun that clothes the trees and flowers. It is the sun that sings in the throats of birds and blooms in the lilacs and roses, that gives joy and beauty to nature. It is the sun that breathes in the fragrant wind from the woods and the meadows enameled with flowers, that babbles in the brook, that glows in the splendor of twilight or the soft gleam of dawn. If we travel by train we utilize solar rays which have been stored in coal. If we eat, it is of the carbon

hoarded by the sun in the field and in the cattle. If we climb a glacier or take in our hands a piece of the ice itself, we behold the sun's work, for without aqueous vapor there can be no ice ; and without the sun, no aqueous vapor.)

X How does it happen that citizens of the earth live thus, strangers to this science of the universe, knowing so little about the heavenly body they inhabit, when nothing in the world is so interesting as the study of nature ! It is probably not so with the inhabitants of the other globes ; in that case the infinite universe would be peopled by beings not knowing even where they are. Surely, if we know neither the heat-giving nature of the sun, nor the position of our planet in the solar system, nor the reason for the change of day and night, of seasons, of years, we are like the blind, and can have but vague, narrow, incorrect and imperfect ideas in regard to creation. Astronomy concerns us much more closely than is generally believed. Not only is it the foremost of the sciences, but at least an elementary knowledge of it is necessary to any education which aims to be thorough, complete, integral, rational.

{ Indeed, without astronomy we should have but inaccurate and mistaken ideas about many things, because we should accept the relative for the absolute. This was so in bygone days, when the earth represented the entire universe, when



Cemille Flammarion

FIVE WEEKS' STUDY OF ASTRONOMY

the traditional conception of creation made people believe that sun, moon, and stars had been created for us, and that our earthly abode was the only world in existence. Still more childish and narrow would be our view were the sky, for instance, entirely hidden from us. Let us imagine for a moment that clouds, instead of forming at a certain altitude and being ephemeral, formed on the surface of the earth and were permanent. Mankind would live in the heart of a perpetual fog. We should never see the sun, or the moon, or the stars. The succession of day upon night would follow without any apparent, well-defined cause. It would be impossible to ascertain the shape of the terrestrial globe or to measure its dimensions; the human race would believe it inhabited a more or less undulating plane. Optical instruments would never have been invented, except, perhaps, those of microscopy. We should err concerning the very foundations of our existence, and we could never obtain any true knowledge of the earth's position, of the laws that govern celestial motion, of the exterior universe, of space, of the infinite. The strangest and most ridiculous systems of philosophy and religion would flourish like weeds beneath this impenetrable fog, and human intelligence would probably always remain earthbound from inability to rise above an inferior condition. Or a slight difference in the constitution of the atmosphere, in its

humidity, in its temperature, would suffice to condemn us to a prison. What is a cloud? What is fog? Humid air become opaque. It is only a matter of proportion. A breath, a mere nothing, and we should be creatures of the meanest intelligence, lost in the lowest depths of ignorance.

Men who have not thought much upon the subject are always astonished when they hear it stated that astronomy is the first and most important of all the sciences. Nevertheless, there is proof of it. Astronomy is preëminently the most comprehensive science, the one which makes the universe known to us—our world and the others, time and space—which touches very closely the great problems of universal life, the destiny of the soul, the infinite and the eternal. What an impetus to thought for even the most indifferent and uninterested minds! Astronomy is the true light of human intelligence. Without it we dwell in a cave and all our conclusions concerning the creation are false. This is a scientific and philosophical truth whose importance we can never too fully appreciate.

If astronomy is the most important science from the philosophical as well as from the purely scientific standpoint, the study of the heavens is also the sublimest of pursuits. It is evening. The sun has set in the clear, western sky at the close of a warm summer day; the air, refreshed,

FIVE WEEKS' STUDY OF ASTRONOMY

is swept by a gentle breeze sweet with the fragrance of mown meadows ; restful silence follows upon the noise and tumult of the day. Earth, lulled to sleep, allows the heavens to reign in their magnificence. The crescent moon hangs in the western sky like a celestial bark descending toward another world. The stars begin to glow, one by one, in the transparent ether according to their brilliancy and position ; one by one we recognize Vega, white and clear, Arcturus with golden rays, the seven stars of Ursa Major, the square of Pegasus, Andromeda, the radiant Capella rising slowly out of the northern mist. Slowly the constellations are traced and our eyes travel among those outlines in the heavens, upon which so many eyes have rested since the Chaldean shepherds were guided by the stars on their journey, and Job, Homer, and Hesiod sang of the Pleiades. And reflecting upon those mortal eyes, sightless today, which have gazed upon these same undying luminous points as brilliant now as in other days, we are impressed by the tremendous difference which separates the earth from the heaven with its vastness, its duration, in the face of which our life is but a fleeting shadow ; and we are conscious of a certain nobleness which comes from the contemplation of its immensity.

Among these celestial lights we distinguish certain ones which shine with a calmer and

less scintillating lustre, and yet seem to be more distended, as if these astral bodies were larger than the stars. Indeed Jupiter, Venus, and Mars appear, at times, immense. If we are familiar with even elementary astronomy we know there is a great difference between stars and planets; the former are at remote distances, to us almost infinite, and are self-luminous, veritable suns in boundless space; the latter are much nearer and form part of our own group, the solar system, and would not be visible but that they are illumined by the sun's light. Take, for instance, Jupiter, which at this time we are admiring in the constellation Sagittarius. Its distance is 626,000,000 kilometres when it is, relatively to us, in opposition to the sun. Not far from Jupiter, in the same constellation, Saturn shines with a dimmer light. Its distance is 1,172,000,000 kilometres. Undoubtedly these numbers seem large, but what are they in comparison with the distances of the fixed stars? The nearest star to us, Alpha in Centaur, is enthroned in space at a distance estimated to be 41,000,000,000,000 kilometres; the second nearest, whose distance has likewise been measured—the sixty-first star in Cygnus—lies at 68,000,000,000,000 kilometres; the third, Sirius, is at 92,000,000,000,000 kilometres. The others are at a hundred, two hundred, three hundred trillions of kilometres—figures so large that they are inconceivable. We shall better understand the

FIVE WEEKS' STUDY OF ASTRONOMY

difference between planetary and stellar distances if we estimate it by the time required for their light to reach us. Everybody knows the velocity of light, which flies through space like an arrow, or to put it better, like lightning, at the rate of 300,000 kilometres a second. Very well then, the ray of light which takes thirty-six minutes to reach us from Jupiter, and sixty-eight from Saturn, must travel four years in order to traverse the distance from the nearest fixed star, seven and a half from the sixty-first star in Cygnus, almost ten from Sirius, twenty-one from Vega, thirty-four from Arcturus, fifty, a hundred and more from the greater number of stars, and even thousands of years from others, flying all the time with the unvarying velocity of 300,000 kilometres a second. In regard to space itself—it is without bounds. A telegram sent today addressed to the frontiers of heaven would *never* reach there.

(We can understand that the astronomer, observing the preëminence of Jupiter, Saturn, Mars, or Venus in a constellation, believes he can almost touch them, so to speak. They are hundreds of thousands of times nearer to us than the stars. The astronomer lives in a sort of intimacy with these neighboring worlds, because the telescope magnifies them perceptibly, and discloses certain details of surface and physical constitution. On the other hand, the stars are so infinitely remote that

THE BOOKLOVERS READING CLUB

they never appear but as luminous points, even with the aid of the strongest telescopic appliances. Saturn reveals its marvelous rings and its eight satellites. Jupiter sails along accompanied by its train of four enormous satellites (to this number a fifth and minute one has recently been added through the discovery of an American, Mr. Barnard), and in its diurnal rotation discloses its cloudy aspects, its belts, both dark and bright, drawn from east to west. Jupiter's varying phases suggest that beneath its hot, thick atmosphere there is in process of formation a world covered with clouds and vapors, a world whose surface is as restless as that of an immense ocean. Mars, from its appearance, may be an inhabited world with seasons similar to our own in severity and twice as long, with polar snows melting in summer and accumulating in winter, with continents, oceans, or vast vegetating, swampy plains, with canals regularly intersecting its immense areas, and with strange topographical features which impress us as belonging to a world full of activity and apparently inhabited by a race superior to our own.

How can we study these other worlds without finding our ideas tremendously enlarged; without seeing the earth grow small and lose itself, as it were, in the unimportant place to which nature has assigned it; without being sure that our globe does not constitute the entire universe, but is only

FIVE WEEKS' STUDY OF ASTRONOMY

an unimportant part of a vast whole, a small province, an ant-hill; without feeling that our existence is but a passing phase in universal and everlasting life?

If the study of the heavens is a mysterious delight to the mind, if astronomy is the science which teaches us more than any other, it is, as well, the best of meditations. Astronomy shows us what is small in that which we believed great, transitory in that which we believed permanent, contingent in that which we believed absolute; it asks us to believe that our seeming loneliness in the heart of the sidereal universe is not a real isolation, but that a real relationship binds all the worlds, that these unknown races are our kindred, and that an infinite solidarity governs the universe. Our horizon is enlarged. We feel that we are not inhabitants of a country or even of a planet, but are citizens of heaven by the same right as would be ours if we lived upon some other orb of the solar system, or of the countless stellar systems lost in the starry deeps.

X One of my readers recently wrote me a letter contesting the conclusion of an article whose final argument was that astronomy improves our moral nature, enlarges our ideas, enlightens our consciences, and elevates our souls. I quote from his letter the following statements: "Of course, if we were all astronomers the world would be more peaceful. But the facts do not prove at all that

science makes man better. Dr. Lapommerais, Eyraud, Ciampi, and Prado certainly could not have been ignorant of the fact that the earth is a planet revolving around the sun, and must even have known other facts ; but that did not prevent them from becoming superlative scoundrels."

It is not futile to reply to these remarks, for they are not the only ones of their kind ; indeed, it is common enough to hear them seriously advanced by certain people. Undoubtedly, knowledge and morality do not necessarily go hand in hand. It is possible to find extremely well educated men who are thieves and even assassins. But who does not feel, judging impartially, that scientific pursuits keep the mind in a serene and peaceful condition, remote from the brutal instincts of animal existence, and that in these there is a safeguard for society? Moreover, it is not of knowledge, of education strictly speaking, that I wished to talk, but of the scientific and, more particularly, the astronomical spirit. I am reproached for asserting that Dr. Lapommerais, an assassin because of his love of money, must have known that the earth is a planet revolving around the sun. I admit his knowledge of the fact ; but what does that prove? It is not enough to know a thing ; it must be felt and understood. A memorable saying of long ago runs, "The letter killeth, the spirit maketh alive." If we pause on

FIVE WEEKS' STUDY OF ASTRONOMY

the surface we cannot penetrate the hidden depths. I insist that he cannot be a bad man who is animated by the philosophical spirit of astronomy.

Let us listen for an instant to the voice of heaven. The infinite surrounds us on all sides. Each star in boundless space is a sun radiating in its own vicinity waves of light, heat, and electricity. The globe we inhabit belongs to a little system of one star, our sun. The universe appears as endless and unbounded space, peopled with myriads of worlds, some of them in embryo, some inhabited and in every stage of intellectual development, some dead; and we feel that the epoch in which we live is of no special importance and is not superior to those which have preceded or those which will follow ours, that the entire human race passes like a shadow, and that this planet is but an infinitesimal representative in the assembly of worlds. Our terrestrial human species seems to our eyes, like its planetary abode, commonplace and imperfect; but with all its imperfection and wretchedness it appears to be gradually progressing by evolution in the unquestionable advance of knowledge and ability.

Furthermore, we now understand that a man's true value does not consist in the fortune he may have inherited from his ancestors, in a certain particle or title before his name, in the social position he may occupy, in his dress, in any external decoration he may wear, but solely in his

THE BOOKLOVERS READING CLUB

moral and intellectual worth. We have the same feelings and opinions in regard to the greatness of nations, and we estimate their value by intellectual, not material, power.

Just one hundred years ago France and her military chief were governing the Continent. Where are they today? Yet what are a hundred years in the history of the human race! One moment, one fleeting instant swiftly gone. Were rulers inspired by the philosophical spirit of astronomy the Chinese would not have been robbed, pillaged, and assassinated in their own country, and the fields of South Africa would not have been stained with the blood of Boers and English. We are barbarians and fools, mistaking appearances for realities; we are just as much slaves as men were in the days when Étienne de la Boétie wrote his fine treatise upon *Voluntary Servitude*.

Men animated with the spirit of astronomy could never be fools, slaves, or barbarians. They never would have made the mistake of revoking the edict of Nantes, of planning the massacre of Saint Bartholomew, of guillotining Lavoisier, Bailly, André Chénier, Fabre d'Eglantine, and other honest men. Astronomical philosophy is a torch that can never become a devastating fire. You may reply that all the sciences, and particularly astronomy, are not for the world in general. This is a mistake. One may be an astronomer in this philosophical sense, just as one may be a

FIVE WEEKS' STUDY OF ASTRONOMY

Catholic, a Protestant, an Israelite, a Mussulman, or a Buddhist ; it is only necessary to understand the elementary astronomical facts, to learn the essential truths of this sublime science, to know the relative position of the earth and its part in the rhythmical harmony of creation. Bad instincts cannot germinate in such a soil. One will laugh at vanity and ambition, at wealth and human folly ; one will live in a pure and quiet atmosphere, taking advantage of no man, either by abusing his credulity or by imposing upon him the yoke of servitude. Such men still form a minority. Politicians are not among them.

The true and the good are branches of the same tree. No science, no line of thought, places us face to face with truth as does astronomy ; none puts us so closely in touch with the infinite. If in the silence of midnight our soul has been borne upward toward the starry shores of the Milky Way ; if it has seen, as in a vision, our errant planet revolving with its sisters around the sun, the sun itself sailing away into the starry desert ; if it has understood that space is boundless, that traveling for a hundred thousand years with the velocity of light could not advance us a single step into its endlessness ; if it has felt but once the awe of infinity and eternity ; then it has seen the history of nations recede like a billow and lose itself in nothingness ; it has looked in vain for the conquests of Alexander and the Pha-

THE BOOKLOVERS READING CLUB

raohs, the empires of Augustus and Charlemagne ; it has been present at the gradual dissolution of ambitious dreams ; it has seen idols with feet of clay crumbling one by one : and nothing remains but spirit, but truth ascertained, but the conquests of thought. Among all the vanquished nations, one alone shines as an unfading star—little Greece, the tiny archipelago in the blue sea, the land of Homer, Pythagoras, Plato, and Phidias, the land of the beautiful, the good, and the true, whose brightness the proudest empire of modern times has never obscured. The man who is thrilled by these imaginings, these thoughts, these convictions, sees in mankind a single family ; in boundaries, arbitrary and harmful divisions ; in all history, a single purpose—the advancement of thought. This scientific philosophy is superior to all creeds, all religions, is untouched and unfettered by material interests, and its adepts live in light, in truth, and in harmony.

Carroll Flannery



How to Make a Sun-Dial:
A Practical Suggestion by
H A R O L D J A C O B Y



How to Make a Sun-Dial:

A Practical Suggestion by

H A R O L D J A C O B Y

Dr. Harold Jacoby received his degree from Columbia College in 1885, and has been professor of astronomy at Columbia since 1894. He is the author of numerous papers on astronomical photography, stellar parallax, and star clusters, which have been published in the journals of scientific societies of Paris, London, St. Petersburg, and New York. His less technical papers appear from time to time in the New York *Evening Post*, the *Boston Transcript*, and various magazines. Dr. Jacoby was a member of the United States eclipse expedition (1889-90) to West Africa. He belongs to several professional organizations in Europe and America, and is corresponding secretary of the New York Academy of Sciences. He contributed the section on astronomy to *The International Year Book*, 1898-1900.

The question is often asked: Why is it desirable to study astronomy? Would it not be better to devote our time to something less abstruse, less far away—in short, to something practical that we can use in our everyday life? There must exist a good answer to this question, just as there must be a reason why students of early human records accept the state of astronomical knowledge as a touchstone by which to test the intellectual development of ancient

peoples. What is there, then, about astronomy distinguishing that science among all branches of human learning? On the one hand, it makes an appeal to the imagination, almost invariably irresistible; for no mind remains unaffected by the vastness inseparable from the heavens. This gives us a poetry of the stars, attractive above and beyond the science itself. Joined to this, again, is another characteristic still more important. The problems of astronomy are the most intricate known to the intellect of man, and yet they are the ones permitting the most exact solutions. Astronomy has been rightly called the "perfect science;" but its perfection does not consist in completeness of knowledge. It is not that our information is all gathered in, that no chance of further success tempts men on to new fields of research, but that the harvest we hope to gain in the future, like those garnered in the past, will be quite perfect of its kind.

It is a singular thing, then, that astronomy, though a leader among the more abstruse sciences, should, nevertheless, be the one that comes nearest to the people in their daily life. For it is to astronomy that we owe the possibility of regulating time and navigating ships. Without the results of observatory work we could neither guide vessels across the ocean nor adjust the time-pieces used in our everyday affairs.

In the present article we propose to explain

FIVE WEEKS' STUDY OF ASTRONOMY

briefly how to construct one of the earliest time-measuring devices, the sun-dial. It is always better in studying science to do something ourselves rather than merely talk about the discoveries of others. Unfortunately, in astronomy observational work of the highest interest is closed to the amateur on account of the lack of costly instruments and observatories ; and theoretical re-

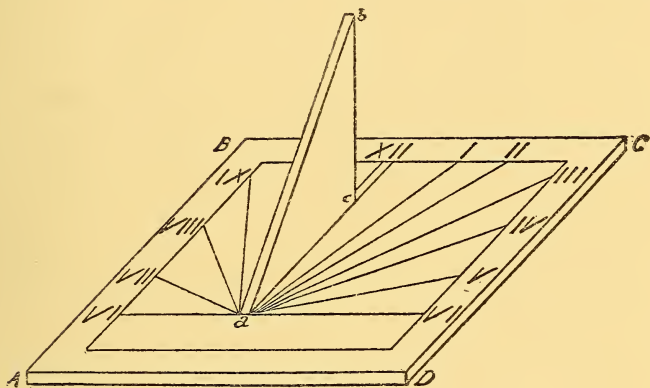

FIG. 1.

searches generally require as a pre-requisite too considerable a knowledge of pure mathematics. The construction of a simple instrument like the sun-dial, however, is possible to everyone and will stimulate a further interest in astronomical study.

Figure 1 shows what a sun-dial should look like. The lines to show the shadow's place at the different hours of the day are marked on the

board A B C D, and this is put on some horizontal flat surface, such as a window-sill or piazza floor. The three-cornered piece of board $a b c$, which is called the *Gnomon*, is fastened to the bottom board A B C D by screws going through A B C D from underneath. The edge $a b$ of the three-cornered board $a b c$ casts the shadow which marks the hours of the day. Of course, it is important that this edge should be straight and perfectly flat and even. Any one handy with tools can make it quite easily, but it is just as satisfactory to mark the right shape on a piece of paper very carefully, and take it to a carpenter, who can cut the board according to the pattern marked on the paper.

Figure 2 shows how to draw the shape of the three-cornered board $a b c$. The side $a c$ should

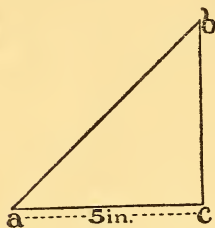

FIG. 2

always be just five inches long. The side $b c$ is drawn at right angles to $a c$, which can be done with an ordinary carpenter's square. The length of $b c$ depends on the place for which the dial is made. The following table gives the length of $b c$

for various cities in the United States. After the length of $b c$ has been marked out, it is merely necessary to complete the three-cornered piece by drawing the side $a b$ from a to b .

FIVE WEEKS' STUDY OF ASTRONOMY

TABLE SHOWING THE LENGTH OF THE SIDE $b c$

<i>Place</i>	<i>Inches</i>	<i>Place</i>	<i>Inches</i>
Albany	4 11-16	New York	4 3-8
Baltimore	4 1-16	Omaha	4 3-8
Boston	4 1 2	Philadelphia	4 3-16
Buffalo	4 11-16	Pittsburg	4 3-8
Charleston	3 1-4	Portland, Me.	4 13-16
Chicago	4 1-2	Richmond	3 15-16
Cincinnati	4 1-16	Rochester	4 11-16
Cleveland	4 1-2	San Diego	3 1-4
Denver	4 3-16	San Francisco	3 15-16
Detroit	4 1-2	Savannah	3 1-8
Indianapolis	4 1-16	St. Louis	3 15-16
Kansas City	3 15-16	St. Paul	5
Louisville	3 15-16	Seattle	5 9-16
Milwaukee	3 11-16	Washington, D. C.	4 1-16
New Orleans	2 7-8		

If it is desired to make a dial for a place not given in the table, it will be near enough to use the distance $b c$ as given for the place nearest to you. But in selecting the nearest place from the table, it is important to take that one of the cities mentioned which is nearest in a north-and-south direction. It does not matter how far away the place is in an east-and-west direction. So instead of taking the place that is nearest on the map in a straight line, take the place to which one could travel by going principally east or west, and very little north or south. The figure is drawn about the right shape for New York. The board used for the three-cornered piece should be about one-half inch thick. But if a window-sill dial is being made, it may be preferable to have it smaller than that described here. It can be made half as big by taking all the sizes and lines in half inches where the table calls for inches.

After marking out the dimensions for the three-cornered piece that is to throw the shadow, you can prepare the dial itself, with the lines that show the place of the shadow for every hour of the day. This you can do in the manner shown in fig. 3. Just as in the case of the three-cornered piece, the dial can be drawn with a pencil di-

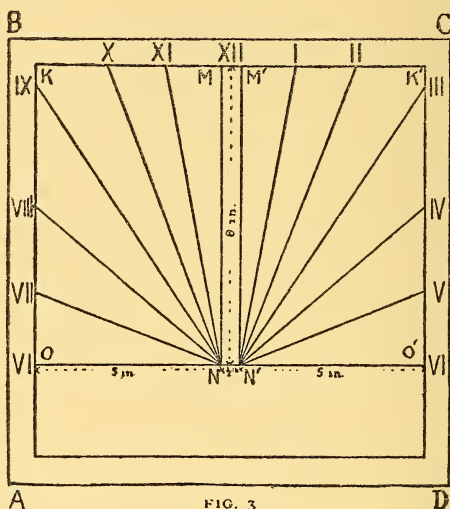

FIG. 3

rectly on a smooth piece of white board, about three quarters of an inch thick, or marked out on a paper pattern and transferred afterward to the board. Perhaps it will be as well to begin by drawing on paper, as any mistakes can then be corrected before commencing to mark the wood.

In the first place you must draw a couple of lines $M N$ and $M' N'$, eight inches long and just far

FIVE WEEKS' STUDY OF ASTRONOMY

enough apart to fit the edge of the three-cornered shadow piece. Since that was to be one-half inch thick, the two lines will also be one-half inch apart. Now draw the two lines NO and $N'O'$ square with MN and $M'N'$, and make the distances NO and $N'O'$ just five inches each. The lines OK , $O'K'$, and the other lines forming the outer border of the dial, are drawn just as shown, OK and $O'K'$ being each eight inches long, the same as MN and $M'N'$. The lower lines in the figure, which are not very important, are to complete the squares. The lines NO and $N'O'$ must be marked with the number VI, these being the lines reached by the shadow at six o'clock in the morning and evening. The points where the VII, VIII, and other hour lines cut the lines OK , $O'K'$, MK and $M'K'$ can be found from the following table. (Page 86.)

In using the table it will be noticed that the line IX falls sometimes on one side of the corner K and sometimes on the other. Thus for Albany the line passes seven and seven-sixteenths inches from O , while for Charleston it passes four and three-eighths inches from M . For Baltimore it passes exactly through the corner K .

The distance for the line marked v from O' is just the same as the distance from O to VII. Similarly, IV corresponds to VIII, III to IX, II to X, and I to XI. The number XII is marked at MM' , as shown. If we desire to add lines (not shown in fig. 3 to avoid confusion) for hours earlier than

THE BOOKLOVERS READING CLUB

six in the morning, it is merely necessary to mark off a distance on the line $K O$, below the point O , and equal to the distance from O to VII. This will give the point where the 5 A. M. shadow line drawn from N cuts the line $K O$. A correspond-

TABLE SHOWING HOW TO MARK THE HOUR LINES

PLACE	<i>Distance from O to the line marked</i>			<i>Distance from M to the line marked</i>		
	VII	VIII	IX	IX	X	XI
	Inches	Inches	Inches	Inches	Inches	Inches
Albany	1 15-16	4 3-16	7 7-16		3 1-16	1 7-16
Baltimore	2 1-8	4 11-16	8		2 7-8	1 7-16
Boston	2	4 5-16	7 7-16		3 1-16	1 7-16
Buffalo	1 15-16	4 3-16	7 7-16		3 1-16	1 7-16
Charleston	2 7-16	5 3-8		4 3-8	2 1-2	1 1-8
Chicago	2	4 5-16	7 7-16		3 1-16	1 7-16
Cincinnati	2 1-8	4 11-16	8		2 7-8	1 7-16
Cleveland	2	4 5-16	7 7-16		3 1-16	1 7-16
Denver	2 1-8	4 1-2	7 11-16		2 7-8	1 7-16
Detroit	2	4 5-16	7 7-16		3 1-16	1 7-16
Indianapolis	2 1-8	4 11-16	8		2 7-8	1 7-16
Kansas City	2 1-4	4 11-16	8		2 7-8	1 5-16
Louisville	2 1-4	4 11-16	8		2 7-8	1 5-16
Milwaukee	1 15-16	4 3-16	7 7-16		3 1-16	1 7-16
New Orleans	2 11-16	5 3-4		4 1-16	2 5-16	1 1-8
New York	2	4 5-16	7 11-16		3 1-16	1 7-16
Omaha	2	4 5-16	7 11-16		3 1-16	1 7-16
Philadelphia	2 1-8	4 1-2	7 11-16		2 7-8	1 7-16
Pittsburg	2	4 5-16	7 11-16		3 1-16	1 7-16
Portland, Me.	1 15-16	4 3-16	7 1-8		3 3-16	1 1-2
Richmond	2 1-4	4 11-16	8		2 7-8	1 5-16
Rochester	1 15-16	4 3-16	7 7-16		3 1-16	1 7-16
San Diego	2 7-16	5 3-8		4 3-8	2 1-2	1 1-8
San Francisco	2 1-4	4 11-16	8		2 7-8	1 5-16
Savannah	2 9-16	5 9-16		4 1-4	2 1-2	1 1-8
St. Louis	2 1-4	4 11-16	8		2 7-8	1 5-16
St. Paul	1 15-16	4 1-16	7 1-8		3 3-16	1 1-2
Seattle	1 13-16	3 15-16	6 5-8		3 3-8	1 1-2
Washington, D. C.	2 1-8	4 11-16	8		2 7-8	1 7-16

ing line for 7 P. M. can be drawn from N' on the other side of the dial.

After you have marked out the dial very carefully, fasten the three-cornered shadow piece to it in such a way that the whole instrument will look

FIVE WEEKS' STUDY OF ASTRONOMY

like fig. 1. The edge $a c$ (fig. 2) goes on $N M$ (fig. 3). The point a (fig. 2) must come exactly on N (fig. 3); and as the lines $N M$ (fig. 3) and $N' M'$ (fig. 3) have been made just the right distance apart to fit the thickness of the three-cornered piece $a b c$ (fig. 2), everything will go together just right. The point c (fig. 2) will not quite reach to M (fig. 3), but will be on the line $N M$ (fig. 3) at a distance of three inches from M . The two pieces of wood will be fastened together with three screws going through the bottom board $A B C D$ (figs. 1 and 3) and into the edge $a c$ (fig. 2) of the three-cornered piece. The whole instrument will then look something like fig. 1.

After your sun-dial has been thus put together, it is merely necessary to set it in the sun in a level place, on a piazza or window-sill, and turn it round until it tells the right time by the shadow. Local time can be obtained from a watch near enough for setting up the dial. Once set right you can screw it down or mark its position, and it will continue to give solar time every day in the year.

If it is desired to adjust the dial very closely, you must go out some fine day and note the error of the dial by a watch at about ten in the morning, and at noon, and again at about two in the afternoon. If the error is the same each time, the dial is rightly set. If not, turning the dial

THE BOOKLOVERS READING CLUB

slightly will make it possible to get the three errors nearly the same. When they are as nearly alike as possible, the dial will be sufficiently near right. The solar or dial time may, however, differ somewhat from ordinary watch time, but the difference will never be great enough to be very serious, nor will it accumulate and increase from day to day, like the error of an imperfect clock.

Harold Jacoby.

In response to our invitation to contribute an article to this course Dr. Jacoby suggested that we reprint the foregoing paper, which he had prepared for the *Cosmopolitan Magazine* (April, 1900). The article has been partly re-written for the present publication.

Illustrative Selections

Illustrative Selections

EARLY ASTRONOMICAL VIEWS

Agnes M. Clerke

Until nearly a hundred years ago the stars were regarded by practical astronomers mainly as a number of convenient fixed points by which the motions of the various members of the solar system could be determined and compared. Their recognised function, in fact, was that of milestones on the great celestial highway traversed by the planets, as well as on the byways of space occasionally pursued by comets. Not that curiosity as to their nature, and even conjecture as to their origin, were at any period absent. Both were from time to time powerfully stimulated by the appearance of startling novelties in a region described by philosophers as "incorruptible," or exempt from change. The catalogue of Hipparchus, probably, and certainly that of Tycho Brahe, some seventeen centuries later, owed each its origin to the temporary blaze of a new star. The general aspect of the skies was thus (however imperfectly) recorded from age to age, and with improved appliances the enumeration was rendered more and more accurate and complete; but the secrets of the stellar sphere remained inviolate.

THE BOOKLOVERS READING CLUB

THE IDEAL ASTRONOMER

Herbert A. Howe

His nervous system is well developed, his eyesight and hearing are fair, and his sense of touch is delicate. His hand is steady under trying circumstances. Nervousness is not a bane of his life, causing him to lose control of himself at moments when every faculty must be at its best, and every muscle obedient to his behest.

When observing a transit of Venus, a repetition of which will not occur during his lifetime, he is, at the critical instants, as cool and collected as if sitting in his office, looking over a new book. This self-control comes from long training; it finds a parallel in the steadiness with which a surgeon's hand, though previously trembling, executes the crucial part of a difficult operation, when the life of the patient hangs in the balance. This ability to exercise self-control is enhanced by the astronomer's plain living and regular habits.

It is a mistake to suppose that he is ordinarily at work at all hours of the night, and tucks in bits of sleep partly by day and partly by night, under the direction of an alarm clock. For the majority of nights are cloudy, so that no observing is done; when the weather is clear he usually has on hand some work which comes during a certain portion of the night. He rarely works all night. Comet hunters are exceptions in the matter of regularity.

FIVE WEEKS' STUDY OF ASTRONOMY

They change their times of observing from night to night, working generally during those hours when the moon is below the horizon; the faint objects which they discover are not commonly readily visible in moonlight.

Astronomers are, on the whole, well educated men, especially those who are the directors of large observatories. Very little can be done in their science without a sound knowledge of elementary mathematics. The principles of physics and mechanics come up continually. An American astronomer who cannot read scientific German and French with considerable ease is often seriously hampered in his work; for he must master the contents of many publications in those languages. Often he wishes to read Italian; a knowledge of Latin and Greek is not infrequently of service.

An astronomer may be very narrow-minded. The ceaseless round of computation by day and observation by night, demanding every iota of his time, has a strong tendency to keep his mind from expanding along any other lines. But if, as usual, he has been through an old-fashioned, now much berated, college curriculum, the liberalizing effect of the four years of study of various branches of knowledge keeps him from undue narrowness. It is noteworthy that men of only moderate mental caliber are the most likely to shrivel up. The mental giants have a many-

sidedness, which leads them to explore other realms of knowledge to a moderate extent. One of the best text-books on political economy published in this country is the work of an astronomer, most of whose time is occupied with directing intricate calculations belonging to the strictly mathematical side of the science.

The director of a large observatory is continually brought into contact with men who are prominent in other lines of scientific work, and with those who have won success in various non-scientific walks of life. He also looks after the business interests of the observatory, and sometimes raises funds for the enlargement of its work. These circumstances effectually prevent his becoming a recluse.



THE EVOLUTION OF THE EARTH

Camille Flammarion

During thousands of centuries the terrestrial globe rolled through space in the condition of a great chemical laboratory. A perpetual deluge of boiling water fell from the clouds upon the burning soil, and rose in vapour in the atmosphere, again to fall. When the temperature became lower than that of boiling water, the vapour liquefied and was precipitated. In the midst of these frightful tempests the terrestrial crust, broken open a thousand times by the convulsions of the

FIVE WEEKS' STUDY OF ASTRONOMY

central fire, vomited out flames, and closed again. The first lands which emerged from the universal ocean were islets of arid and sterile granite. Later on, from the bosom of the waves, the first semi-fluid combinations of carbon formed the earliest rudimentary attempts at life, protoplasm, a substance which scarcely merits the name of organism, which is no longer a simple mineral, but is still neither vegetable nor animal. The primitive plants, the seaweeds, which float inert in the ocean, were already in progress. The primitive animals, the zoöphytes, elementary molluscs, corals, medusas, were also progressing. Imperceptibly, age by age the planet loses its roughness, the conditions of life are improved, beings multiply and become different from the primitive stock, acquiring organs, at first rough and rudimentary, afterwards developed and perfected.

The primeval age, in which the new-born life was represented by the seaweeds, crustacea, and vertebrates still destitute of a head, seems to have occupied alone 53 hundredths of the time which has elapsed since the earth became habitable.

The primary period which succeeded it had for its type the establishment of the coal vegetation and the reign of fishes, and appears to have occupied the following 31 hundredths.

The secondary period, during which the splendid coniferous vegetation ruled the vegetable world, while enormous saurian reptiles dominated

the animal world, lasted for the following 12 hundredths. The earth was then peopled with fantastic beings, devoting themselves to perpetual combats in the midst of ungovernable elements.

We have here, then, according to the comparative thickness of the geological formations which have been deposited in these successive epochs, 96 hundredths of past time occupied by a living nature absolutely different from that which now embellishes our globe, a nature relatively formidable and coarse, and as distinct from what we know as that of another world. Who would have then dared to raise the mysterious veil of futurity and divine the future unknown epoch when, by a new transformation, Man should appear upon the planet?

The tertiary period, during which appeared only mammals and animal species, which show more or less physical affinity with the human species, came, then, to gather up the inheritance of the primitive ages, and to substitute itself for the preceding period. Its duration did not even reach three-hundredths of the total time.

Finally, the quaternary age saw the birth of the human species, and of cultivated plants. It represents but a hundredth of the scale of time, more probably half a hundredth.

How these grand contemplations enlarge the ideas which we habitually form of nature! We imagine that we go very far back in the past in

FIVE WEEKS' STUDY OF ASTRONOMY

contemplating the old pyramids still standing on the plains of Egypt, the obelisks engraved with mysterious hieroglyphics, the silent temples of Assyria, the ancient pagodas of India, the idols of Mexico and Peru, the time-honoured traditions of Asia and of the Aryans, our ancestors, the instruments of the stone age, the flint weapons, the arrows, the lances, the knives, the sling-stones of our primitive barbarism—we scarcely dare to speak of ten thousand, of twenty thousand years. But even if we admit a hundred thousand years for the age of our species, so slowly progressive, what is even this compared with the fabulous succession of ages which have preceded us in the history of the planet !

In allotting one hundred thousand years to the quaternary age, the age of our present nature, we see that the tertiary period would have reigned during five hundred thousand years previously, the secondary period during two millions three hundred thousand, the primary period during six millions four hundred thousand, and the primæval period during ten millions seven hundred thousand. Total : twenty millions of years ! And what is even this history of life compared with the total history of the globe, since it has taken more than three hundred millions of years to render the earth solid and to reduce its external temperature to 200° ? And how many millions must we still add to represent the time which elapsed be-

tween the temperature of 200° and that of 70° , the probable maximum possible for organic life!



TIME AND ITS DISTRIBUTION

Herbert A. Howe

No endeavor is made to keep a standard clock right, for the constant changes which would be necessary would introduce intolerable disturbances into the clock's performance. It is therefore permitted to go on, month after month, without alteration, its errors and rates being determined from time to time by observations of the stars.

We have seen how an astronomer gets time, and how he endeavors to keep it. We shall now see how he disseminates it for the benefit of the country at large.

Here electricity comes into play; as a telegraph operator by touching his key can make any sounder on the line tick, so a clock may be arranged to accomplish the same end. While the second-hand is flying from one second to the next one, a tooth of a wheel mounted on the same arbor as the second-hand strikes a miniature telegraph key, and the signal is sent. One of the clocks at the United States Naval Observatory at Washington sends a signal over the Western Union wires to distant cities day after day, and thousands of telegraphic instruments tick as the signal passes.

FIVE WEEKS' STUDY OF ASTRONOMY

The sending of the signal is but a small part of the work of disseminating the time. In some cities a time ball is hoisted to the top of a pole a few minutes before noon and released at noon by an electrical impulse. In others the fire bells are rung at the same hour. The Western Union Telegraph Company controls a system of clocks, which are set automatically once a day when a signal is sent to them. Thus a business man may have reasonably correct time in his office, if he is willing to pay the small rental charged by the company. The system conduces to the accurate running of trains, for every important railway station contains a telegraph office.

The system of standard meridians, which has been adopted by the railroads and by the most important municipalities, is a great convenience. The trains in the eastern portion of the United States are governed by Eastern Standard time, which is five hours later than Greenwich time, and is not far from local time at Philadelphia. Central Standard time is six hours later than Greenwich time, and is used in the Mississippi Valley and adjacent states. It is nearly the same as local time at St. Louis. Mountain time differs from Greenwich time by seven hours and dominates the semi-arid region formerly known as the Great American Desert. The seven-hour meridian passes through Denver. Pacific time, one hour slower still, is the standard for the Pacific

THE BOOKLOVERS READING CLUB

coast. The eight-hour meridian passes centrally through California.

Two further improvements upon this plan may yet be made. There should be no insurmountable difficulty in having the time the same throughout any given state. The fact that the meridian by which Central time is governed runs near the Mississippi River much facilitates the grouping of the states in such a way that the time which should be adopted in each one is easily remembered.

A further desirable change, which would be more difficult of accomplishment, because of the conservatism of even so progressive a people as Americans, is counting the hours continuously through the day from one to twenty-four. The designations, a. m. and p. m., would then be unnecessary. This system has already been tried upon the Canadian Pacific Railway, and is in force in Italy. Its advantages are simplicity and accuracy. Astronomers already have a twenty-four-hour day, which begins at noon.

The business man prefers to have the date change at midnight, when he is usually asleep. The astronomer finds it inconvenient to change the date at midnight, when he is frequently engaged in observation. The astronomical day begins twelve hours later than the civil day; January 5, 10 a. m., is January 4, 22 hours, by astronomical reckoning. March 16, 8 p. m., is March 16,

FIVE WEEKS' STUDY OF ASTRONOMY

8 hours, astronomically reckoned. Astronomers have of late years discussed the advisability of making their day begin at the same time as the civil day, viz., at midnight, but they have not yet made the change.

Europe is much in advance of America in the matter of time distribution. The city of Paris is supplied with a system of electrical clocks, and also with a system of pneumatic clocks, which, as their name indicates, are driven by compressed air. The standard clocks are so numerous that any one may learn the time accurately with little trouble. Many small municipalities have extensive systems of electrical dials.

One of the most elaborate systems of time distribution is to be found in Great Britain. The Royal Observatory at Greenwich is the source of accurate time, which is telegraphed over the United Kingdom. A time ball is dropped at Greenwich for the use of ships in the Thames. Another at Deal serves the shipping in the Downs. The great clock at Westminster Palace is regulated in accordance with the telegraphic signals. Through the post-office department are sent signals which are utilized in various ways, such as the regulation of clocks, the striking of bells, and the firing of guns.

SPECTRUM GRATINGS

Agnes M. Clerke

Of many ingenious improvements in spectroscopic appliances the most fundamentally important relate to what are known as "gratings."

These are very finely striated surfaces by which light-waves are brought to interfere, and are thus sifted out, strictly according to their different lengths, into "normal" spectra. Since no universally valid measures can be made in any others, their production is quite indispensable to spectroscopic science. Fraunhofer, who initiated the study of the diffraction spectrum, used a real grating of very fine wires; but rulings on glass were adopted by his successors, and were by Nobert executed with such consummate skill that a single square inch of surface was made to contain 100,000 hand-drawn lines. Such rare and costly triumphs of art, however, found their way into very few hands, and practical availability was first given to this kind of instrument by the inventiveness and mechanical dexterity of two American investigators. Both Rutherford's and Rowland's gratings are machine-ruled, and reflect, instead of transmitting the rays they analyse; but Rowland's present to them a very much larger diffractive surface, and consequently possess a higher resolving power. The first preliminary to his improvements was the production, in 1882, of a faultless screw, those previously in use having

FIVE WEEKS' STUDY OF ASTRONOMY

been the inevitable source of periodical errors in striation, giving, in their turn, ghost-lines as subjects of spectroscopic study. Their abolition was not one of Rowland's least achievements. With his perfected machine a metallic area of $6\frac{1}{4}$ by $4\frac{1}{4}$ inches can be ruled with exquisite accuracy to almost any degree of fineness; he considers, however, 43,000 lines to the inch to be the limit of usefulness. The ruled surface is moreover concave, and hence brings the spectrum to a focus without a telescope. A slit and an eyepiece are alone needed to view it, and absorption of light by glass lenses is obviated—an advantage especially sensible in dealing with the ultra- or infra-visible rays.



STELLAR SPACES

Camille Flammarion

In forming an idea of the immensity of the desert which surrounds our solar system some comparisons will be more easily grasped than the figures themselves. Representing by 1 yard the distance which separates us from the sun, and placing the sun at the centre of the system, that globe would be one-third of an inch in diameter, our planet would be quite a small point of $\frac{1}{300}$ of an inch in diameter, placed at 1 yard, and Neptune, the frontier of our planetary republic, would be a ball of $\frac{1}{80}$ of an inch placed at *ninety-eight feet*. To mark the distance of the nearest star,

it should be removed to 170 miles, or from Paris to beyond Brussels; such is the proportion between the extent of the solar system and interstellar immensity. There, the first sun met with would be represented by a sphere of a size similar to that which we have supposed for our sun.

Let us suppose that a celestial traveller were carried out in space by a motion of such rapidity that he would in twenty-four hours pass over the distance which extends from the sun to Neptune (more than two thousand millions of miles). This velocity is so enormous that we would cross the Atlantic from Havre to New York in less than the tenth of a second. Our traveler would in forty-eight minutes pass over the space extending from the sun to the earth, and would arrive at Neptune at the end of the first day. But, having thus traversed the whole system, he would still travel in a straight line and with the same velocity for twenty-five years before reaching the first star, and he would then have the same voyage before him to arrive at the second, and so on. The earth would have disappeared from his view in the middle of the first day, and all the planets would have vanished before the end of the third day; then the sun himself, gradually diminishing in brightness, would year by year sink to the rank of a star.

We have remarked above that if we could throw a bridge from here to the sun, this celestial

FIVE WEEKS' STUDY OF ASTRONOMY

bridge would be composed of *eleven thousand six hundred arches as wide as the earth*. Suppose a pillar at each extremity of this bridge. It would be necessary to repeat *this same bridge two hundred and seventy-five thousand times* to reach the nearest sun ; that is to say, this marvel of imaginary architecture, more wonderful than all the fables of ancient mythology, and more fabulous than all the tales of *The Thousand and One Nights*, would be composed of 275,000 piers, distant from each other by 93 millions of miles.

A star, a sun, may cause an explosion. If the noise of such a terrible conflagration could be transmitted to us, we should not hear it till the end of *three million seven hundred and ninety-five thousand years !*

We may add, further, that an express train which, at the constant velocity of 37 miles an hour, would pass over in 266 years the space which separates us from the sun, would not arrive at the nearest star, Alpha Centauri, until after an uninterrupted run of nearly *seventy-three millions of years !*

The sphere of the sun's attraction extends through the whole of space out to infinity. To speak accurately and minutely, there is not in the whole universe any particle of matter which does not feel to some extent the attractive influence of the sun, and even that of the earth, and of all

other bodies still lighter ; each atom in the universe has an influence on every other atom, and in displacing objects on the surface of the earth—in sending a ship from Marseilles to the Red Sea—we disturb the moon in its course. But, as we have seen, the action is in the direct ratio of the masses and in the inverse ratio of the square of the distances. The influence of the sun on the stars is not only excessively small with reference to the velocity of motion which it would produce in a given interval of time, but there is here only the influence of one star among its equals. On all sides, moreover, the reign of the sun is limited, for there are innumerable suns in all directions, and the sphere ruled by each star is as limited as that of our own star, so that everywhere we should find regions where his influence would be neutralised.

The sphere of the sun's attraction extends, nevertheless, out to and beyond the distance of Neptune. Strictly speaking, it extends indefinitely out to points where, in various directions, it meets with spheres of attraction of the same intensity.



COMETS AND PLANETS

Camille Flammarion

Four principal characteristics distinguish comets from planets: (1) their nebulous aspect and their tails, often considerable; (2) the length

FIVE WEEKS' STUDY OF ASTRONOMY

of the elliptical orbits which they describe; (3) the inclination of these orbits, which, instead of lying in the plane of the ecliptic, or at least in the zodiac, like those of the planets in general, are inclined at all degrees up to a right angle, and sometimes carry the comets to the polar constellations; (4) the directions of their motions, which, instead of being performed in the same direction as those of planets, are, some direct, others retrograde, and appear to be strangers to any unity of plan. From these circumstances the certain conclusion follows that comets have not the same origin as the planets, that they did not originally belong to the solar system, that they travel through immensity, that they may be transported from one sun to another, from star to star, and that those which revolve round our sun have been caught in their passage by his attraction, having had their course curved and closed by the influence of the planets of our system.



THE NEBULAR HYPOTHESIS

Agnes M. Clerke

We cannot doubt that the solar system, as we see it, is the result of some process of growth—that, during innumerable ages, the forces of Nature were at work upon its materials, blindly modeling them into the shape appointed for them from the beginning by Omnipotent Wisdom. To set ourselves to inquire what that process was, may be

an audacity, but it is a legitimate, nay, an inevitable one. For man's implanted instinct to "look before and after" does not apply to his own little life alone, but regards the whole history of creation, from the highest to the lowest—from the microscopic germ of an alga or a fungus to the visible frame and furniture of the heavens.

Kant considered that the inquiry into the mode of origin of the world was one of the easiest problems set by Nature ; but it cannot be said that his own solution of it was a satisfactory one. He, however, struck out in 1755 a track which thought still pursues. In his *Allgemeine Naturgeschichte* the growth of sun and planets was traced from the cradle of a vast and formless mass of evenly diffused particles, and the uniformity of their movements was sought to be accounted for by the uniform action of attractive and repulsive forces, under the dominion of which their development was carried forward.

In its modern form, the "Nebular Hypothesis" made its appearance in 1796. It was presented by Laplace with diffidence, as a speculation unfortified by numerical buttresses of any kind, yet with visible exultation in having, as he thought, penetrated the birth-secret of our system. He demanded, indeed, more in the way of postulates than Kant had done. He started with a sun ready made, and surrounded with a vast glowing atmosphere, extending into space out beyond the orbit

FIVE WEEKS' STUDY OF ASTRONOMY

of the farthest planet, and endowed with a slow rotatory motion. As this atmosphere or nebula cooled, it contracted; and as it contracted, its rotation, by a well-known mechanical law, became accelerated. At last, a point arrived when tangential velocity at the equator increased beyond the power of gravity to control, and equilibrium was restored by the separation of a nebulous ring revolving in the same period as the generating mass. After a time, the ring broke up into fragments, all eventually reunited in a single revolving and rotating body. This was the first and farthest planet.

Meanwhile the parent nebula continued to shrink and whirl quicker and quicker, passing, as it did so, through successive crises of instability, each resulting in, and terminated by, the formation of a planet, at a smaller distance from the centre, and with a shorter period of revolution than its predecessor. In these secondary bodies the same process was repeated on a reduced scale, the birth of satellites ensuing upon their contraction, or not, according to circumstances. Saturn's ring, it was added, afforded a striking confirmation of the theory of annular separation, and appeared to have survived in its original form in order to throw light on the genesis of the whole solar system; while the four first discovered asteroids offered an example in which the *debris* of a shattered ring had failed to coalesce into a single globe.

This scheme of cosmical evolution was a characteristic bequest from the eighteenth century to the nineteenth. It possessed the self-sufficing symmetry and entireness appropriate to the ideas of a time of renovation, when the complexity of nature was little accounted of in comparison with the imperious orderliness of the thoughts of man. Since it was propounded, however, knowledge has transgressed many boundaries, and set at naught much ingenious theorising. How has it fared with Laplace's sketch of the origin of the world? It has at least not been discarded as effete. The groundwork of speculation on the subject is still furnished by it. It is, nevertheless, admittedly inadequate. Of much that exists it gives no account, or an erroneous one. The march of events certainly did not everywhere—even if it did anywhere—follow the exact path prescribed for it. Yet modern science attempts to supplement, but scarcely ventures to supersede it. . . .

But recent science raises many objections to the details, if it supplies some degree of confirmation to the fundamental idea of Laplace's cosmogony. The detection of the retrograde movement of Neptune's satellite made it plain that the anomalous conditions of the Uranian world were due to no extraordinary disturbance, but to a systematic variety of arrangement at the outskirts of the solar domain. So that, were a

FIVE WEEKS' STUDY OF ASTRONOMY

trans-Neptunian planet discovered, we should be fully prepared to find it rotating, and surrounded by satellites circulating from east to west. The uniformity of movement, upon the probabilities connected with which the French geometer mainly based his scheme, thus at once vanishes.

The excessively rapid revolution of the inner Martian moon is a further stumbling-block. On Laplace's view, *no* satellite can revolve in a shorter time than its primary rotates; for in its period of circulation survives the period of rotation of the parent mass which filled the sphere of its orbit at the time of giving it birth. And rotation quickens as contraction goes on; therefore, the older time of axial rotation should invariably be the longer. This obstacle can, however, it seems, be turned.

More serious is one connected with the planetary periods, pointed out by Babinet in 1861. In order to make them fit in with the hypothesis of successive separation from a rotating and contracting body, certain arbitrary assumptions have to be made of fluctuations in the distribution of the matter forming that body at the various epochs of separation. Such expedients usually merit the distrust which they inspire.

Again, it was objected by Professor Kirkwood in 1869 that there could be no sufficient cohesion in such an enormously diffused mass as the planets are supposed to have sprung from, to account for

the wide intervals between them. The matter separated through the growing excess of centrifugal speed, would have been cast off, not by rarely recurring efforts, but continually, fragmentarily, *pari passu*, with condensation and acceleration. Each wisp of nebula, as it found itself unduly hurried, would have declared its independence, and set about revolving and condensing on its own account. The result would have been a meteoric, not a planetary system.

Moreover, it is a question whether the relative ages of the planets do not follow an order just the reverse of that concluded by Laplace. Professor Newcomb holds the opinion that the rings which eventually constituted the planets divided from the main body of the nebula almost simultaneously, priority, if there were any, being on the side of the inner and smaller ones; while in M. Faye's cosmogony, the retrograde motion of the systems formed by the two outer planets is ascribed—on grounds, it is true, of dubious validity—to their comparatively late origin.

This ingenious scheme is designed, not merely to complete, but to supersede that of Laplace, which, undoubtedly, through the inclusion by our system of oppositely directed rotations, forfeits its claim simply and singly to account for the fundamental peculiarities of its structure.

M. Faye's leading contention is that, under the circumstances assumed by Laplace, not the two

FIVE WEEKS' STUDY OF ASTRONOMY

outer planets alone, but the whole company, must have been possessed of retrograde rotation. For they were formed—*ex hypothesi*—after the sun; central condensation had reached an advanced stage when the rings they were derived from separated; the principle of inverse squares consequently held good, and Kepler's laws were in full operation. Now particles circulating in obedience to these laws can only—since their velocity decreases outward from the centre of attraction—coalesce into a globe with a *backward* axial movement. Nor was Laplace blind to this flaw in his theory; but his effort to remove it, though it passed muster for the best part of a century, was scarcely successful. His planet-forming rings were made to rotate *all in one piece*, their outer parts thus necessarily traveling at a swifter linear rate than their inner parts, and eventually uniting, equally of necessity, into a *forward*-spinning body. The strength of cohesion involved may, however, safely be called impossible, especially when it is considered that nebulous materials were in question. . . .

In one form or another, if we speculate at all on the development of the planetary system, our speculations are driven into conformity with the broad lines of the Nebular Hypothesis—so far, at least, as admitting an original material unity and motive uniformity. But we can see now, better

than formerly, that these supply a bare and imperfect sketch of the truth. We should err gravely were we to suppose it possible to reconstruct, with the help of any knowledge our race is ever likely to possess, the real and complete history of our admirable system. "The subtlety of nature," Bacon says, "transcends in many ways the subtlety of the intellect and senses of man." By no mere barren formula of evolution, indiscriminately applied all round, the results we marvel at, and by a fragment of which our life is conditioned, were brought forth; but by the manifold play of interacting forces, variously modified and variously prevailing, according to the local requirements of the design they were appointed to execute.

Stimulative Questions



he questions which follow bear upon the topics of the course as presented in the handbook. They aim to stimulate further research as well as to test the amount of information gained. Full and thoughtful answers, written out if possible, will greatly assist in changing transitory impressions into permanent ones, and will make a fixed point of departure for further study.

STIMULATIVE QUESTIONS

1. Give approximately the time when each of the following named men lived, and the thing for which each is best known to astronomers: Hipparchus, Ptolemy, Copernicus, Tycho Brahe, Kepler, Galileo, Newton, Laplace, William Herschel, Halley, Fraunhofer, Adams, Leverrier.

2. Name the discoveries of the past century which seem to you to have done the most to advance our knowledge of the heavenly bodies.

3. What is the meaning of each of the following terms: horizon, celestial pole, zenith, nadir, latitude, longitude, ecliptic, zodiac, altitude, azimuth, declination, right ascension?

4. Is the earth a perfect sphere? If not, by how much does it differ from a perfect sphere? Is there any reason why it should not be a perfect ellipsoid of revolution? What is an ellipsoid of revolution?

5. Captain Slocum, in his account of his voyage alone around the world, says that many of the eminent men among the Boers believe the earth to be flat, and that they so maintained in conversation with him. By what arguments could you persuade an intelligent person of the truth?

6. Why is there a difference between the length of the sidereal day and that of the day by the sun-dial?

7. Do you ever see the sun directly overhead?

8. As you look at the Pole Star on a summer evening, on which side is the Great Dipper?

9. Did you ever see Jupiter and the Great Dipper at the same time without turning the eyes?

THE BOOKLOVERS READING CLUB

10. Can the sun ever shine in at a north window? Give a reason for your answer.

11. Why is it possible to see the sun when it is actually just below the horizon?

12. What is meant by mean solar time?

13. What is the Gregorian calendar? What is the meaning of "old style" applied to a date of one hundred and fifty years ago?

14. What is the shape of the earth's orbit?

15. What is meant by aphelion and perihelion?

16. What is precession?

17. What is meant by the phases of the moon? How do you explain them?

18. How much of the moon's surface do we ever see? Why do we not see more?

19. Did you ever see an eclipse of the moon? If so, you probably saw the whole surface of the moon throughout the eclipse. Explain this and the red color.

20. Why do we not have an eclipse of the moon and an eclipse of the sun every month?

21. Name the planets in their order from the sun.

22. Have you ever seen Mercury? Why is it not more often seen?

23. Describe the appearance of the planet Venus at its brightest. Where would you look for it?

24. How does Jupiter appear as seen through your glass? If you have seen any of his satellites, describe their appearance also.

25. Give some estimate of the brilliancy of the sun's surface.

FIVE WEEKS' STUDY OF ASTRONOMY

26. What is supposed to be the condition of the sun?
 27. How is the sun's supply of heat kept up?
 28. What is a sun-spot, and what is believed to be its cause?
 29. How has the constitution of the sun been determined?
 30. What are meant by the corona and the prominences? What are the prominences supposed to be?
 31. Explain the production of tides. What is meant by tidal friction?
 32. What has been the effect of tidal friction in the past in the case of the earth and the moon?
 33. Describe the fundamental differences between a reflecting and a refracting telescope. Name the advantages and the disadvantages of each form.
 34. What is gained by using a large aperture in a telescope?
 35. Why are the great telescopes made so long?
 36. Name the great telescopes of the world.
 37. What is the use of a "transit circle" or "meridian circle?"
 38. Give a brief description of the spectroscope. What does it tell us?
 39. What is "parallax?"
 40. How are the distances of the stars and planets determined?
 41. How are the masses of the heavenly bodies determined?
 42. Describe the relations of the bodies known to belong to the solar system.
-

THE BOOKLOVERS READING CLUB

43. What is the appearance of the surface of Mercury so far as it is known?
44. Why is the length of Mercury's day the same as that of its year, and why has it probably no satellite?
45. What appear to be the characteristics of the atmosphere of Venus?
46. Sketch briefly the history of the moon.
47. Sketch briefly the history of the earth and its probable future.
48. Describe the prominent formations on the moon's surface as seen through your glass.
49. What is the general appearance of the planet Mars?
50. What do we know about the canals of Mars?
51. What are believed to be the conditions prevailing on Mars as to land, water, and atmosphere?
52. What reasons are there for believing that Mars cannot be inhabited by beings like ourselves?
53. How many satellites has Mars, and what peculiarities do they show?
54. What are the asteroids, and what are the theories in regard to their origin?
55. Describe the appearance of Jupiter as seen through a powerful telescope.
56. How does Jupiter compare, in mass and size, with the earth?
57. What is supposed to be the condition of Jupiter?
58. How many moons has Jupiter?
59. Describe the appearance of Saturn.

FIVE WEEKS' STUDY OF ASTRONOMY

60. Of what do Saturn's rings consist? Why must this be the case?
61. What is supposed to be the condition of Saturn?
62. What is likely to be the complete history of the rings of Saturn?
63. How many satellites has Saturn, and how do they compare in size with our own moon?
64. What is the most striking peculiarity of the system of Uranus?
65. What is probably the condition of Uranus?
66. State briefly what is known of Neptune.
67. Give the history of the discovery of Neptune.
68. Name the two most remarkable comets of the past century.
69. What is believed to be the origin of the tails of comets?
70. What is supposed to be the origin of meteors?
71. Name six of the familiar bright stars and tell where to look for them.
72. How many stars can you count in the Pleiades?
73. About what is the distance of the nearest star?
74. How are the stars designated?
75. Toward what point is the solar system moving, and how is it determined?
76. What are binary stars?
77. How may the speed of a star in the line of sight be determined?
78. State briefly Laplace's theory of the formation of the solar system.

Topics *for* Special Papers *and for* Open Discussion

1. The naming of the constellations.
2. Famous astronomers.
3. The systems of Ptolemy and Copernicus.
4. Newton's work for astronomy.
5. Tides and their influence in the formation of satellites.
6. The harvest moon.
7. Topography of the moon.
8. The making of great telescopes.
9. The spectroscope's story of the stars.
10. Reflectors vs. refractors.
11. Celestial photography.
12. The formation of the solar system.
13. What are sun-spots?
14. The future of Saturn.
15. The life of a comet.
16. Variable stars.
17. Structure of the heavens.
18. Meteoritic and regenerative hypotheses of the sun's heat.
19. Is the sun growing hotter or colder?
20. Is Mars inhabited?
21. Is Venus inhabited?
22. The origin of the asteroids.
23. What is the cause of the brightness of comets' tails?

Supplementary Reading

Recommended for this course by

PROFESSOR C. A. YOUNG

1. A Popular History of Astronomy during the Nineteenth Century. By Agnes M. Clerke.

A book of great interest, recommended highly by Professor Young. It is complete and accurate, yet simple and straightforward, so that one not especially versed in astronomy can read it with interest and profit.

2. The Story of the Heavens. By Robert Stawell Ball.

A careful study of the whole field of astronomy for average readers. It is profusely illustrated, many of the plates being colored. "All Sir Robert Ball's books are well written and interesting, and he knows his subjects so that there are seldom any blunders of fact or statement in his pages."—*Professor Young*.

3. Popular Astronomy: A General Description of the Heavens. By Camille Flammarion.

Translated from the French by J. E. Gore. A very comprehensive and elaborate book, fully illustrated. It is distinctively popular in its object.

4. A Text-book of Astronomy. By George C. Comstock.

A good, careful text-book. The author "has endeavored to concentrate attention upon those parts

THE BOOKLOVERS READING CLUB

of the subject that possess special educational value." Directions are given for observations with simple apparatus. It does not attempt to cover the entire field of astronomy.

5. *A Study of the Sky.* By Herbert A. Howe. A book for beginners. It is simple and accurate. Helpful for locating the constellations, and fixing the elementary lore of the subject.
6. *Elements of Astronomy.* By Simon Newcomb. "It is very good and may be safely taken as authoritative as far as it goes."—*Professor Young.*

Modesty forbade Professor Young to name two books which we are unwilling to omit. We therefore add the following:

7. *The Sun.* By C. A. Young. Professor Young's book is recognized as the final authority on the subject it treats. It is not a popular book, though it is simple and straightforward in its style.
8. *General Astronomy.* By C. A. Young. An excellent text-book for the serious student.

Twenty-Five Reading Courses

No. 1—PROBLEMS IN MODERN DEMOCRACY

Among the contributors to the handbook accompanying this course are ex-President Cleveland; Woodrow Wilson, Professor of Politics, Princeton University; Henry J. Ford, author of *Rise and Growth of American Politics*; and Henry D. Lloyd, author of *Newest England*. The books for the course are selected by Mr. Cleveland.

No. 2—MODERN MASTERS OF MUSIC

Among the contributors to the handbook accompanying this course are Reginald de Koven, Dr. W. S. B. Mathews, editor of *Music*; James G. Huneker, editor of *Musical Courier*; Henry E. Krehbiel, musical critic *New York Tribune*; and Gustave Kobbé, author of *Wagner's Life and Works*. The most attractive reading course ever offered to lovers of music.

No. 3—RAMBLINGS AMONG ART CENTRES

Among the contributors to the handbook accompanying this course are F. Hopkinson Smith, Dr. John C. Van Dyke, Dr. John La Farge, President of the Society of American Artists; Kenyon Cox and Dr. Russell Sturgis. The handbook is attractively illustrated. Mr. Smith and Dr. Van Dyke are responsible for selecting the books to be read.

No. 4—AMERICAN VACATIONS IN EUROPE

This course is the next best thing to going abroad oneself. Among the contributors to the handbook are Frank R. Stockton, Jeannette L. Gilder, editor of *The Critic*; Mrs. Schuyler Crowninshield and George Ade. The handbook has a fine portrait frontispiece.

No. 5—A STUDY OF SIX NEW ENGLAND CLASSICS

The books for this course are selected by Dr. Edward Everett Hale. Among the contributors to the handbook are Dr. Hale, Julian Hawthorne, Mrs. James T. Fields and Dr. Edward Waldo Emerson. Dr. Emerson is a son of Ralph Waldo Emerson. This is one of the most attractive courses in the entire series.

No. 6—SHAKESPEARE'S ENGLISH KINGS

The plays are selected for this course by H. Beerbohm Tree, the well-known English actor, and the books to be read in connection with the plays are selected by Sir Henry

THE BOOKLOVERS READING CLUB

Irving. Among the other contributors to the handbook are Prof. Edward Dowden, acknowledged the greatest Shakespearean scholar of Great Britain, Dr. Hiram Corson, of Cornell University; Dr. William J. Rolfe and Dr. Hamilton W. Mabie. The handbook is very attractively illustrated.

No. 7—CHARLES DICKENS: HIS LIFE AND WORK

Among the contributors to the delightful handbook accompanying this course are George W. Cable, the well-known novelist; Irving Bacheller, author of *Eben Holden*; Andrew Lang, the distinguished English writer; Amelia E. Barr, the novelist; and James L. Hughes, author of *Dickens as an Educator*. The books to be read are selected by Mr. Cable and Mr. Bacheller. The handbook is beautifully illustrated.

No. 8—CHILD STUDY FOR MOTHERS AND TEACHERS

Among the contributors to the handbook accompanying this course are Margaret E. Sangster, Nora Archibald Smith, Anne Emilie Poulson, Charlotte Perkins Gilman, Lucy Wheelock and Kate Gannett Wells. Mrs. Sangster selects the books to be read.

No. 9—INDUSTRIAL QUESTIONS OF THE DAY

The following distinguished writers on economic problems contribute to the handbook accompanying this course: President Jacob Gould Schurman, of Cornell University; Jeremiah Whipple Jenks, Professor of Political Science, Cornell University; Richard Theodore Ely, Director of the School of Economics, Political Science and History, University of Wisconsin; Sidney Webb, Lecturer London School of Economics and Political Science, Member London County Council; and Carroll Davidson Wright, United States Commissioner of Labor.

No. 10—FLORENCE IN ART AND LITERATURE

Among the contributors to the handbook accompanying this course are William Dean Howells, Dr. Russell Sturgis, Frank Preston Stearns, author of *Midsummer of Italian Art*, *Life of Tintoretto*, etc.; Dr. William Henry Goodyear, Curator Fine Arts Museum of Brooklyn Institute; and Lewis Frederick Pilcher, Professor of Art, Vassar College. The handbook has some attractive illustrations.

No. 11—STUDIES OF EUROPEAN GOVERNMENTS

The books have been selected specially for this course by the Rt. Hon. James Bryce, of the English House of Commons, and the Hon. Andrew D. White, United States Ambassador to Ger-

THE BOOKLOVERS READING CLUB

many. Among the other contributors to the handbook are Jesse Macy, Professor of Constitutional History and Political Science, Iowa College; and John William Burgess, Professor of Political Science and Constitutional Law, and Dean of the Faculty of Political Science, Columbia University.

No. 12—FAMOUS WOMEN OF THE RENAISSANCE

Among the contributors to the handbook accompanying this course are Col. Thomas Wentworth Higginson, Margaret Deland and Charlotte Brewster Jordan. The handbook has several very interesting illustrations.

No. 13—THE MODERN CITY AND ITS PROBLEMS

Among the contributors to the handbook accompanying this course are Dr. Frederic W. Speirs; Dr. Albert Shaw, editor of *The Review of Reviews*; Bird S. Coler, Comptroller of the City of New York, author of *Municipal Government*; and Charles J. Bonaparte, Chairman of the Executive Committee of the National Municipal League. The books are selected by Dr. Speirs.

No. 14—STUDIES IN APPLIED ELECTRICITY

This is without exception the most attractive and the most helpful reading course ever offered to students of electricity. Thomas A. Edison selects the books specially for these studies. Among the other contributors to the handbook are Dr. Edwin J. Houston, Dr. Elihu Thomson, Carl Hering, Ex-President of the American Institute of Electrical Engineers; and Arthur V. Abbott, Chief Engineer of the Chicago Telephone Company.

No. 15—FIVE WEEKS' STUDY OF ASTRONOMY

Among the contributors to the handbook accompanying this course are Charles A. Young, Professor of Astronomy, Princeton University; Sir Robert S. Ball, Professor of Astronomy, Cambridge University, and Director of Cambridge Observatory, England; Camille Flammarion, founder of the Astronomical Society of France, and author of *Marvels of the Heavens, Astronomy, etc.*; George C. Comstock, Director of Washburn Observatory, University of Wisconsin; and Harold Jacoby, Professor of Astronomy, Columbia University. The study programme includes contributions from the most famous astronomers of England and France.

No. 16—RECENT ENGLISH DRAMATISTS

Lovers of the best modern dramas will find much pleasure in these studies. Among the contributors to the handbook are Brander Matthews, Professor of Literature, Columbia University;

THE BOOKLOVERS READING CLUB

Dr. William Winter, Dramatic Critic for the New York *Tribune*; Dr. Harry Thurston Peck, Editor of *The Bookman*; Louise Chandler Moulton; and Norman Hapgood, the well-known writer of dramatic criticism. The handbook has some interesting illustrations.

No. 17—STUDIES IN CURRENT RELIGIOUS THOUGHT

The books are chosen for the course by Dr. Lyman Abbott and Dr. Washington Gladden. Among the contributors to the handbook are Dr. Samuel D. McConnell, Rector of Holy Trinity Church, Brooklyn; President William DeWitt Hyde, of Bowdoin College; Dr. Amory H. Bradford, Editor of *The Outlook*; Dr. Henry Collin Minton, of San Francisco Theological Seminary, late Moderator of the Presbyterian General Assembly; Dr. H. W. Thomas, Pastor of the People's Church, Chicago; and Dr. Theodore T. Munger, Pastor of the United Congregational Church, New Haven. For clergymen and laymen who wish to stimulate the growth of a theology which is in harmony with the best thought of the time we recommend this handbook and this reading course.

No. 18—THE GREATER VICTORIAN POETS

The books are selected for this course by Thomas Bailey Aldrich. Among the other contributors to the handbook are Thomas R. Lounsbury, Professor of English, Yale University; Dr. T. M. Parrott, of Princeton University; and Marie Ada Molineux, author of *The Phrase Book of Browning*.

No. 19—OUT-OF-DOOR AMERICANS

Among the contributors to the handbook accompanying this course are John Burroughs, Ernest Seton-Thompson, President David Starr Jordan, of the Leland Stanford Junior University; Ernest Ingersoll and Hamlin Garland. Lovers of nature will find delight in the outlines and recommendations of this course.

No. 20—THE WORLD'S GREAT WOMAN NOVELISTS

Mrs. Humphry Ward, the well-known English novelist, is the first contributor to the handbook accompanying this course. The other contributors are Elizabeth Stuart Phelps Ward, Mary E. Wilkins, Agnes Repplier, Katherine Lee Bates, Professor of English, Wellesley College; and Oscar Fay Adams. The handbook contains some interesting illustrations.

No. 21—AMERICAN FOUNDATION HISTORY

Hon. Henry Cabot Lodge selects the books for this course. Among the other contributors are Albert Bushnell Hart, Professor of American History, Harvard University; John Bach

THE BOOKLOVERS READING CLUB

McMaster, Professor of American History, University of Pennsylvania ; Reuben Gold Thwaites, Secretary of the State Historical Society of Wisconsin, author of *The Colonies* ; Paul Leicester Ford, author of *Janice Meredith* ; and Andrew Cunningham McLaughlin, Professor of American History, University of Michigan.

No. 22—STUDIES IN AMERICAN LITERARY LIFE

Professor Barrett Wendell and Professor Lewis E. Gates, of Harvard, and Dr. Horace E. Scudder, late editor of *The Atlantic Monthly*, contribute to the handbook accompanying this course. For a brief stimulative and instructive course in American literature nothing better could possibly be offered.

No. 23—STUDIES IN RECENT FRENCH FICTION

Alcée Fortier, Professor of Romance Languages, Tulane University of Louisiana, has chosen the books for this reading course. Among the contributors to the handbook are the three distinguished French writers, Edouard Rod, Ferdinand Brunetière and Paul Bourget, and the notable American critic, Dr. Benjamin W. Wells, author of *Modern French Literature and A Century of French Literature*.

No. 24—THE ENGLISH BIBLE : HOW WE GOT IT

The contributors to this course include President William R. Harper, of the University of Chicago ; John Franklin Genung, Professor of Rhetoric, Amherst College ; William Newton Clarke, Professor of Christian Theology, Colgate University ; and Richard G. Moulton, Professor of English Literature, University of Chicago. The handbook is a very interesting and instructive volume in itself.

No. 25—THE MECHANISM OF PRESENT DAY COMMERCE

In Preparation. The books are selected by the Hon. Lyman J. Gage, Secretary of the Treasury.

L. OF C.
BINDERY
1903

LIBRARY OF CONGRESS

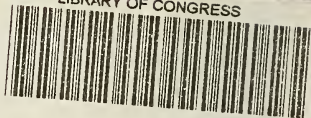

0 003 538 546 0

